

## CHAPTER 9

### FIELD KITCHEN COMPONENTS

#### EQUIPMENT

This chapter discusses and describes the various components associated with the field kitchen whether established with the MKT or using various tents. It also identifies the importance of equipment status and readiness and the causes of and solutions to problems.

#### Status and Readiness

Food advisors must monitor food service equipment status and readiness rates. They are key problem indicators for field equipment. Equipment status is the percentage of authorized equipment on hand. The PBO maintains information on equipment status. The readiness rate is the percentage of equipment that is fully mission capable. To determine the equipment readiness rate, divide the number of days during the reporting period the equipment is fully mission capable by the number of days the equipment is on hand in the unit, and multiply the resulting number by 100. If under ULLS, ensure the automated maintenance forms are completed and maintained in accordance with the most recent Maintenance Management Update. (ULLS replaces DD Form 314 and DA Form 2408-14 for determining deferred maintenance.) Food advisors can monitor their equipment status by using the ULLS generated forms or the manual forms listed below. DA Pamphlet 738-750 explains the use of these forms. Commanders and food advisors must ensure that entries on these forms are accurate and show the true status of equipment. Monitoring these records helps determine the causes of equipment problems.

**DD Form 314.** This form provides for recording of data used to figure the readiness rate for each item of equipment. It also provides a format for programming

and recording the scheduled services required by the equipment technical manuals and lubrication orders at the organizational level.

**DA Form 2404.** This is used to record operator services, equipment inspections, faults, performance of operator services, corrective maintenance actions, and to order parts.

**DA Form 2407.** This is used to request higher echelon maintenance.

#### Problems

Problems may be caused by operation, maintenance, or supply failures. For example, if inspections and services are not being scheduled or performed, then resulting problems would probably be due to maintenance failures. If equipment is serviced regularly, but equipment readiness is below standard, personnel may be misusing the equipment or they may not be performing services correctly. DA Forms 2404 and DD Forms 314 will indicate whether items of equipment deadlined for maintenance are waiting for parts or waiting for repair. If a large percentage of equipment is waiting for parts, there is a supply failure. The FOS or food advisor may need to contact the supporting supply activity to request information on the status of requisitions. Reports on equipment waiting in DS maintenance are provided by the maintenance control section at the supporting DSU.

#### Problem Solutions

Once the problem has been determined, the food advisor should brief the supply officer or commander. Include the statistics that show there is a problem and the probable cause of the problem. Suggest ways to

solve the problem. Be prepared to support recommendations. Ask the commander or supply officer for a decision on how to handle the problem and what action to take. Take the necessary action and keep the commander informed of your progress.

### M2 BURNER UNIT

The M2 burner unit (Figure 9-1) is the heat source for the M59 field range, KCLFF, MKT, and the SC. The M2 burner unit has a U-shaped tank. For more information and operating instructions on the burner unit, see TM 10-7360-204-13&P. The FOS must ensure that the cooks operate burner units safely and in a manner which protects the environment. They must be trained in fire prevention, and they must know what to do if a fire starts.

#### Fire Prevention and Environmental Protection

Be sure that all personnel follow these rules when operating the M2 burner unit:

- Make a firm, level, and well-drained foundation, free of burnable material, for the range.
- Make sure that the burner unit is at least 15 meters (50 feet) from any open flame before filling. The gasoline storage area should also be 15 meters from the kitchen tent or MKT.
- Never pressurize the tank while the flame is burning or when the burner is hot, as escaping gasoline vapors will ignite.
- Wipe up spilled fuel on the burner unit. Vapors from spilled fuel can catch fire or explode if they contact the burner flame or heat from a hot burner. Do not permit fuel spills to absorb into the ground. Place contaminated dirt in plastic bags for retrograde and disposal.
- Do not operate the burner unit when the pressure gauge reaches or exceeds 25 pounds per square inch.
- Do not operate a burner unit with a pressure gauge that has not been equipped with the correct safety color code indicator (green 0-25, yellow 25-35, and red 35-60). Do not operate the M2 burner unit with a cracked or broken lens on the air pressure gauge.

- Do not tighten joints while the burner unit is in operation.
- *NEVER* put more than one burner unit in the M59 range.

#### Fire Fighting

Be sure that all personnel know what to do if a fire starts while using the M2 burner unit. When a fire starts follow these steps:

- First try to close the flame valve. If you close the flame valve, pull the burner unit from the range cabinet.
- If the flame valve cannot be closed, use a fire extinguisher to put out the fire in the cabinet.
- After the fire is out, remove the burner unit from the kitchen.
- After the unit cools, let out the air pressure from the fuel tank by loosening the fuel tank filler cap.

#### WARNING

**Do NOT operate the burner in an unventilated space. Buildup of carbon monoxide gas could lead to INJURY or DEATH.**

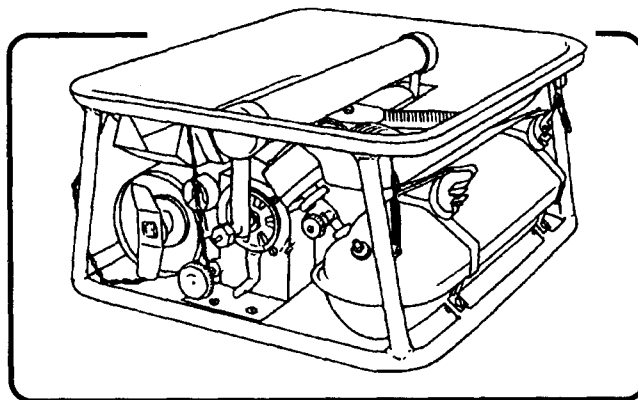

Figure 9-1. The M2 burner unit

#### M59 FIELD RANGE OUTFIT AND ACCESSORIES

The M59 field (LIN R14154) range is portable and can be adapted to many different cooking configurations. One field range outfit may be used to cook

for up to 50 people. Field ranges are grouped together to cook for more than 50 people. Each field range comes with pots, pans, and cooking and serving utensils. One accessory outfit is authorized for every one to four ranges. Figure 9-2 shows the M59 field range. Figure 9-3 shows the accessory kit. For more information on the field range and accessory outfit, see TM 10-7360-204-13&P.

### Using the Field Range

The M59 field range can be used to bake, roast, boil, grill, and deep-fat fry foods by putting the burner unit in the correct position. The range may also be used as a hot line or steam table. The burner unit can be used in either the top or bottom position. Figure 9-4, page 9-4, shows the field range with the burner unit in the top position. When the burner unit is used in the top position, open the slide shutters on the field range cabinet. Figure 9-5, page 9-4, shows the field range with the burner unit in the bottom position. Close the slide shutters on the field range cabinet when the unit is in the bottom position.

#### WARNING

**Before placing a burner unit in either position, check to be sure that the other position is empty. Operating a field range with two burner units could lead to INJURY or DEATH.**

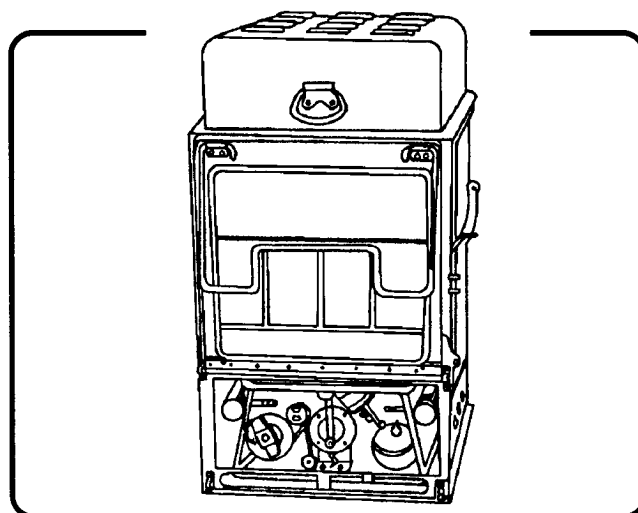

Figure 9-2. M59 field range

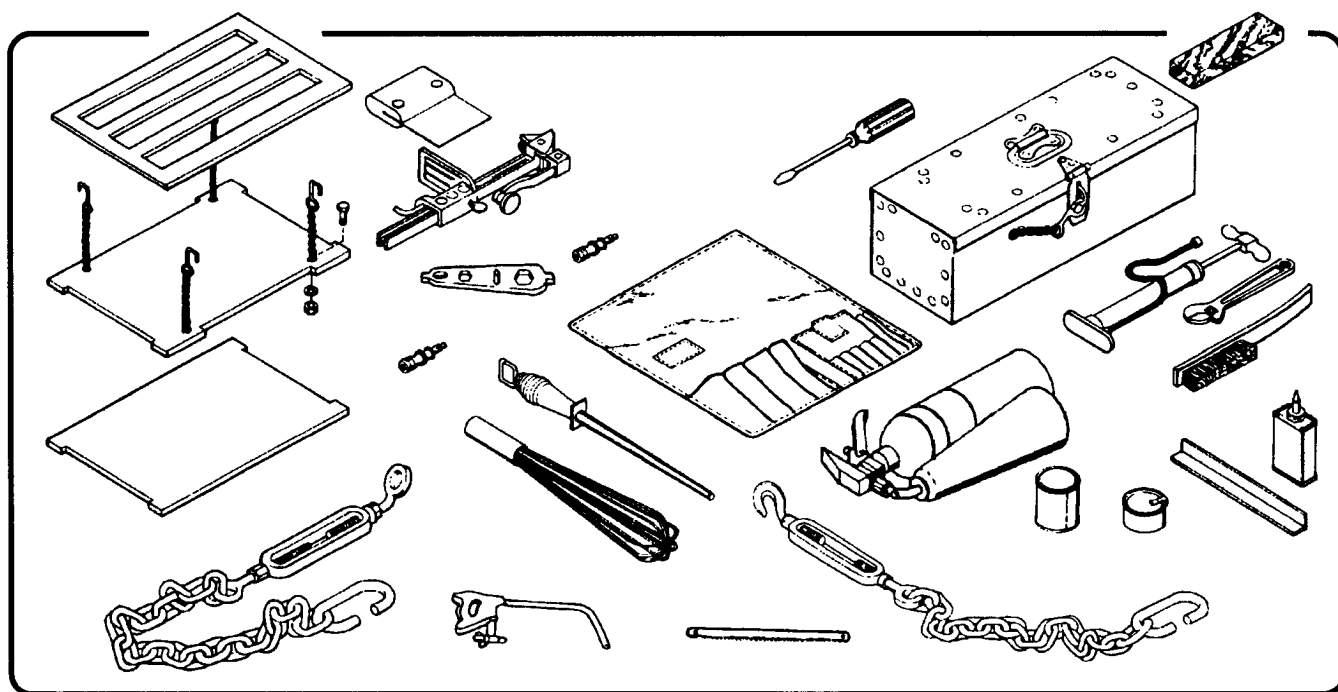

Figure 9-3. Field range accessory kit

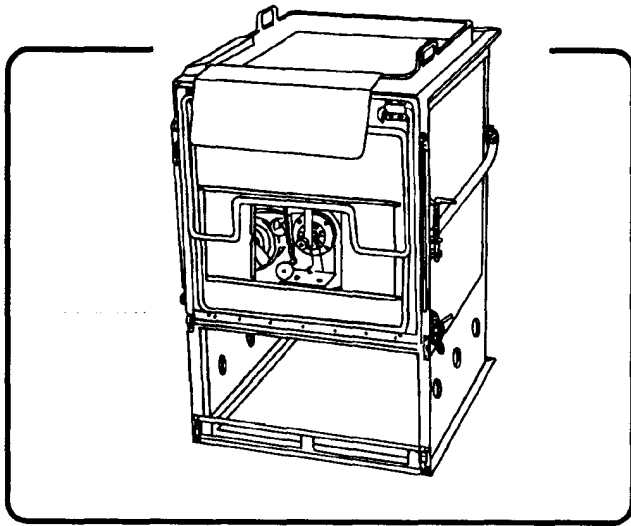

Figure 9-4. Field range with burner in top position

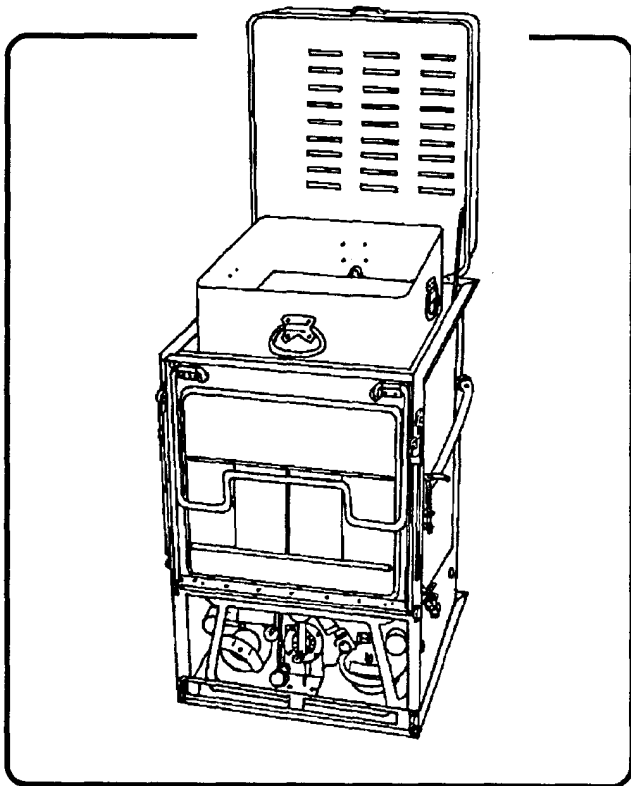

Figure 9-5. Field range with burner unit in bottom position

### Roasting

Put the burner unit in either the top or bottom position. Place the baking and roasting pan on the top of the field range and preheat it to the proper temperature. Place roasts in the pan. Cover the pan if you are cooking the roasts by the moist-heat method. Close the door and lid.

### Boiling

Put the burner unit in the bottom position. Use either the 40- or 60-quart cooking pot. Attach the splash plate and cover it. Place the cooking pot in the cooking pot cradle and put them in the cabinet of the field range. Close the door and lid. When you need a double boiler, put 21 liters (22 quarts) of water in the 60-quart pot. Place the pot in the cradle. Put a 40-quart pot in the 60-quart pot and then cover the 40-quart pot.

### Baking

Three baking racks come with the field range as part of the accessory outfit. You can bake foods inside the cabinet or on top of it in a baking and roasting pan. You can bake cakes, bread, biscuits, cobblers, or cookies using the rack set and the burner unit in the bottom position. Preheat the cabinet to the proper temperature. Place a pan on each shelf. During the baking time, be sure to rotate the pans three times. If you do not have a baking rack set, follow these steps for preparing cakes, biscuits, and cobblers.

**Cakes, cookies, and breads.** Place the burner unit in the bottom position. Put the empty baking and roasting pan on the field range top. Preheat the pan to the proper temperature. Place the sheet pan in the baking and roasting pan. (The five indentations in the bottom of the baking and roasting pan let the heat flow evenly around the sheet pan.) Close the cabinet door and lid. When the cake, cookies, or bread are done, use two forks to remove the sheet pan as shown in Figure 9-6, page 9-5.

**Biscuits and cobblers.** You can bake biscuits and cobblers with the burner unit in either the top or the bottom position.

*Top position.* Place an empty baking and roasting pan on-top of the field range. Preheat to the desired temperature. Put a sheet pan of biscuits or cobbler in the empty baking and roasting pan. Close the cabinet door and lid. **NOTE: Make sure that the slide shutters on the cabinet door are open.**

*Bottom position.* Open the cabinet lid and place the baking and roasting pan on top of the field range. Preheat the pan before placing the product inside. Close the cabinet door and lid. In both positions, remove the sheet pan as shown in Figure 9-6.

### Deep-Fat Frying

Place the burner unit in the top position and close the cabinet door. **NOTE: Make sure that the slide shutters on the cabinet door are open.** Put the baking and roasting pan on top of the field range. Fit the long arm protector over the front side of the cabinet and the edges of the pan. Fit the short arm protector over the edge of the pan on the side where you plan to work. Fill the pan one-third to one-half full of shortening. Heat the shortening to the required temperature. Check the temperature with a thermometer or drop a bread cube into the hot shortening. If the bread browns in 20 seconds, the shortening is hot enough to use. After you have fried the food, use the skimmer to remove the food from the pan.

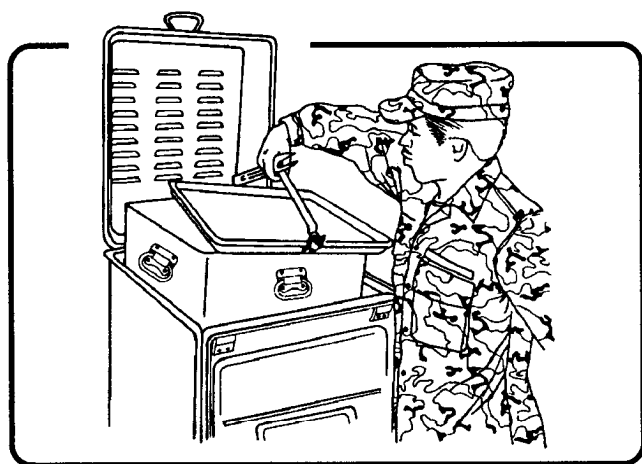

Figure 9-6. Removing sheet pan from the baking and roasting pan

### Grilling

Place the burner unit in the top position and close the cabinet door. **NOTE: Make sure that the slide shutters on the cabinet door are open.** Turn the cover of the baking and roasting pan upside down and fit it onto the griddle supports. Fit the long arm protector over the front edge of the griddle and cabinet. Fit the short arm protector over the side edge of the griddle and cabinet where you are working. You may need to grease the griddle lightly. (The MKT has its own special griddle which is placed over two burner units.)

### Hot Line

Place the burner unit in the top position of the range and close the cabinet door. **NOTE: Make sure that the slide shutters on the cabinet door are open.** Put the baking and roasting pan on top of the range, fill the pan one-third to one-half full of water, place a warmer adapter inside of the baking and roasting pan to form a holder for up to six insulated food container inserts. Fit the long arm protector over the front side of the cabinet and the edge of the pan. Fit the short arm protector over the edge of the pan on the side you plan to work and/or serve the food. Heat the water in the pan to maintain the internal temperature of the food products at 140 degrees Fahrenheit or above. Place the inserts with the hot food products inside the warmer adapter as needed during the meal service period. A product thermometer must be used to check food temperatures.

### IMMERSION HEATERS

Immersion heaters are used to heat water for clean up operations at the field kitchen. Two types of immersion heaters are the standard model and the preway model. Figure 9-7, page 9-6, shows what they look like. The models look very much alike, with the main difference being the two column stacks on the heater body. Make sure your cooks know how to preheat and light the model with which your unit is equipped. Operating instructions are on the data plate attached to the burner unit cover. In addition, TM 5-4540-202-12&P and TM 10-4500-200-13

discuss the immersion heater in detail. Details for set up and operation of the immersion heater are in Chapter 12. The Army plans to replace the immersion heater (and mess kit laundry lines) with the deployment of the SC. This conversion will depend on finding and deployment of the SC.

### SANITATION CENTERS

Food service sanitation requires that certain standards be maintained during field kitchen

operations. The SC (Figure 9-8), provides a means for effectively maintaining sanitation.

### Equipment

The equipment for the SC, which includes the TEMPER tent (LIN S33399; NSN 7360-01-277-2558), is shown in Figure 9-9, page 9-7. Assemble equipment as described in the following paragraphs.

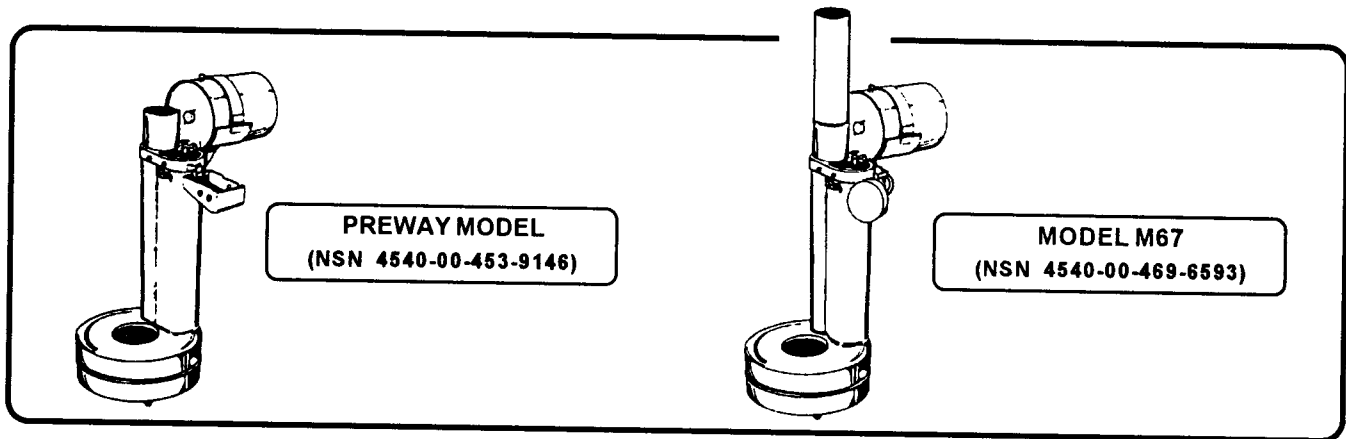

Figure 9-7. Immersion heaters

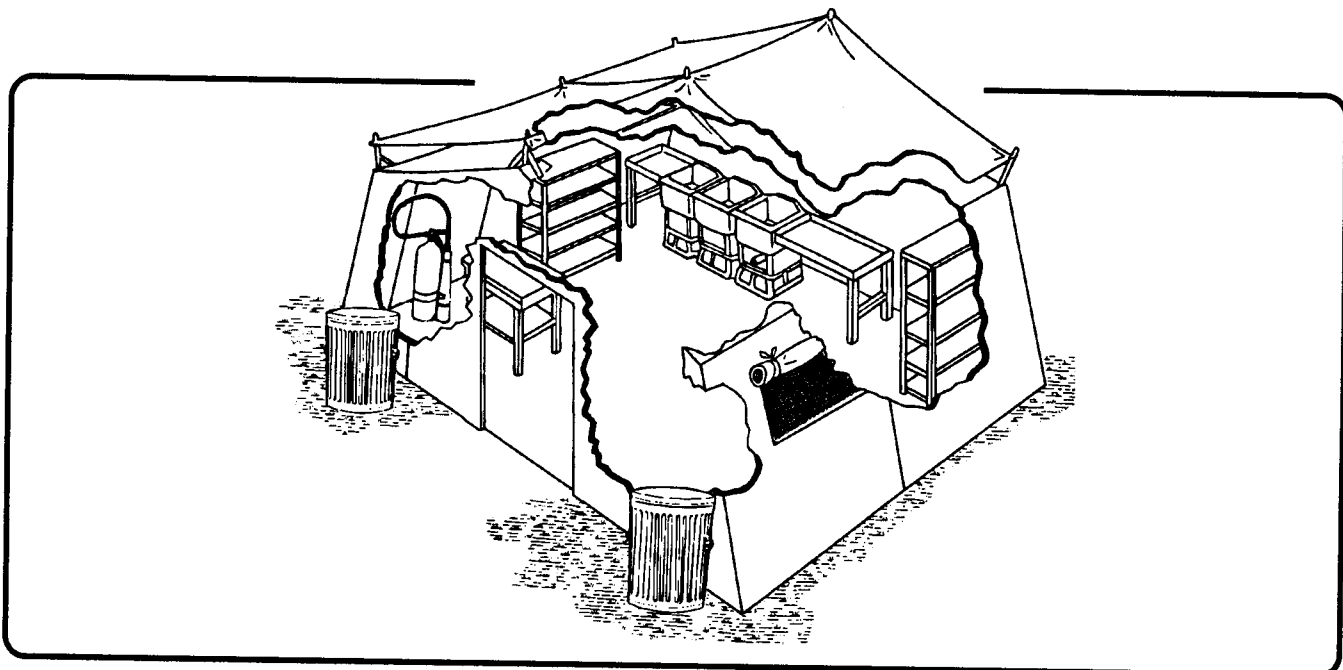

Figure 9-8. Sanitation Center

**Sink assembly.** The sinks come complete with two racks inside each sink (a burner rack for the M2 burner and a rack base). Assemble the sinks as shown in Figures 9-10 and 9-11, page 9-8.

**Worktable.** Assemble the worktable. Place it in front of the three sinks.

**Storage rack assembly.** Assemble the storage rack and place it in a convenient area of the tent.

**Trash cans.** Place the two 32-gallon-capacity plastic trash cans inside the tent entrance. You can also place the trash barrel outside the tent, if that is more convenient. One can is used for food waste (plate scraping, leftovers, and vegetable culling) and the other is for nonfood waste (cans, bottles, boxes, and paperware).

- Three field sinks and three sink covers
- Two drain tables
- One worktable
- Two storage racks
- Three burner units
- One tent, extendable, modular, utility (16 feet by 20 feet)
- One gasoline lantern
- One 50-foot drain hose assembly
- One fire extinguisher
- Three thermometers for the sink and three brackets for the thermometers
- Two plastic trash barrels
- Two sink immersion racks
- Two sink adapters (to connect sinks at the top)

Figure 9-9. Sanitation Center equipment

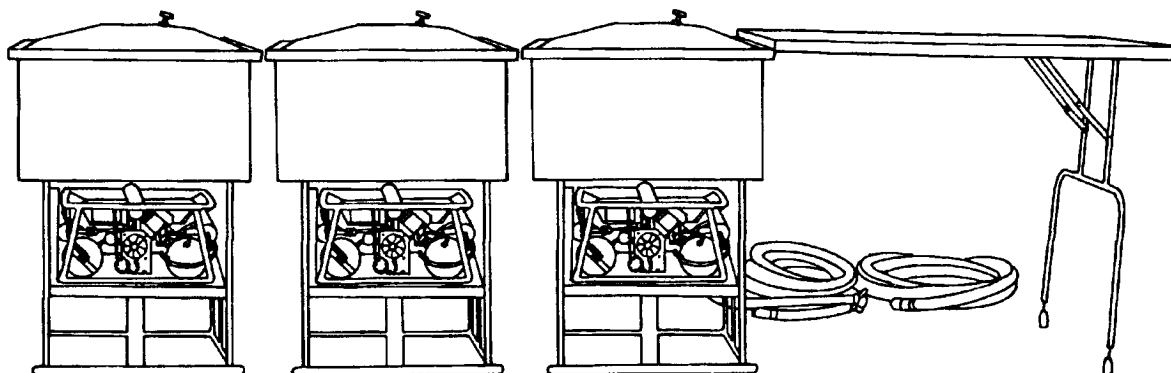

1. Take out the first rack for the M2 burner.
2. Take out the rack base. Invert it, and use it as a foundation.
3. Set the M2 burner rack on the rack base.
4. Center the sink on top of the M2 burner back with the drain assembly to the rear.
5. Repeat steps 1 through 4 with the remaining two sinks.
6. Place the three sinks next to each other by the window at the rear or left side of the tent. Attach the sinks together with sink adapters. Attach the drain table to the side of the two end sinks. The two drain tables will hook onto the top edge of the sink. Adjust the fold-out legs for balance. Attach thermometers and thermometer brackets to each sink.
7. Attach the drain hose assembly to the rear of each sink; then attach the 50-foot length of drain hose to the drain hose assembly, and extend it to the proper location (Figure 9-11, page 9-8).
8. Close the sink drains.

Figure 9-10. Sink assembly

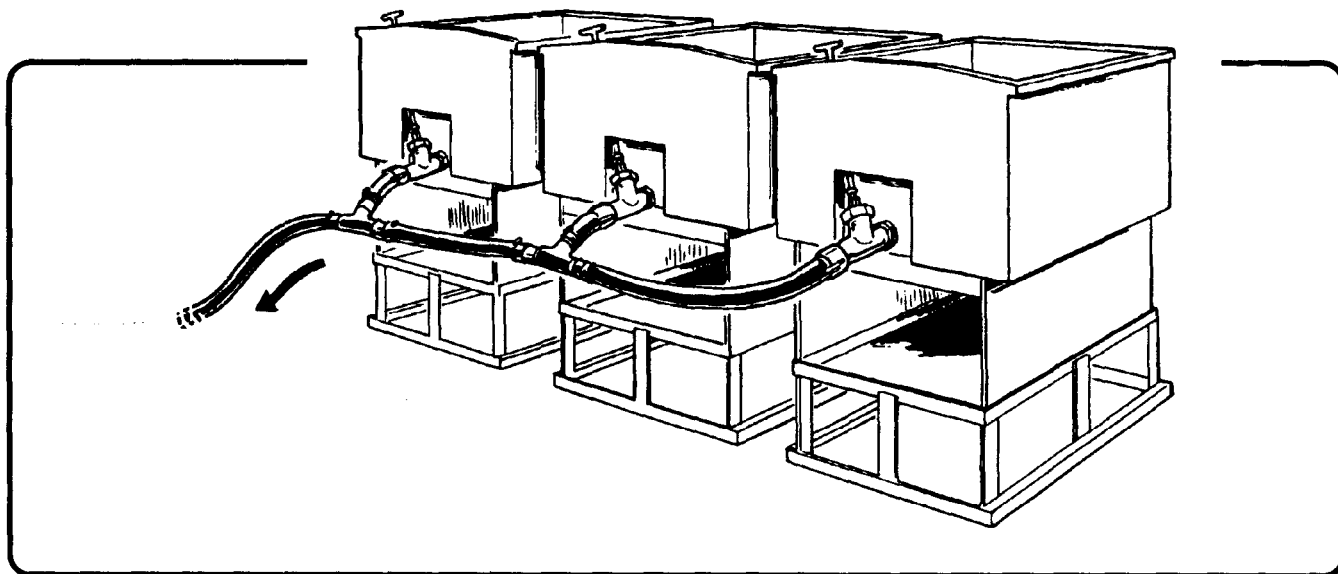

Figure 9-11. Drain hose assembly

## INSULATED FOOD CONTAINERS

Insulated food containers (LIN H83817) are used to keep hot foods hot and cold foods cold. Each container has three aluminum inserts with tight fitting covers. Each insert may be filled to 5 1/3-liters- (5 2/3-quart-) capacity. Hot and cold food should be stored in separate containers. The insulated food container may also be used to transport T-Ration pans.

### Heating and Filling

A properly heated container will keep food warm for three to five hours. However, keep in mind that *TB MED 530 states that PHF held in an insulated food container for more than four hours must be discarded.* Before you put hot food in the container, heat the container as described in the following steps:

- Remove the inserts.
- Pour 2 quarts (1.9 liters) of boiling water into the container.
- Replace the inserts.
- Close the container lid and secure the latches diagonally.

- Let stand for at least 30 minutes.
- Open and remove the inserts.
- Pour water from the container.
- Put hot food in the insert and replace the insert cover (with gasket).
- Place the filled inserts in the container.
- Close and fasten the container lid by securing the latches diagonally.

### Chilling and Filling

If you need to chill a container before you put cold food into it, follow the steps described below:

- Remove the inserts.
- Put crushed ice or 2 quarts of ice water in the container.
- Close the container lid and secure the latches.
- Let stand for 30 minutes.
- Pour ice or water from the container.
- Put food in the inserts and fasten the lids.
- Place the filled inserts in the container.
- Close and fasten the container lid by securing the latches diagonally.

### Labeling Containers

Label each food container after you fill it. A good label can be made by placing a strip of masking tape across the top of the container lid. Write the menu item, the number of servings, the date, the time the item was placed in the container, and "Consume by \_\_\_\_\_ or Discard" (fill in the time 4 hours after the container was filled) on the tape. The NSNs for the labels on the top of the insulated food container are 7690-01-224-6411, 7690-01-220-3274, or 7690-01-223-2521.

### Transporting Food

If the food is to be carried to other sites, use a code letter or color to identify each site. Make sure that each site has a complete menu. Write the menu items, the number of servings, the date and time prepared, "Consume by \_\_\_\_\_ or Discard", and the site code on each container label. For feeding small units, put separate inserts of a meat, a starch, and a vegetable in one insulated food container.

### Cleaning the Container

Clean the insulated food container and the inserts before and after every use. Never immerse the food container in water. Remove the inserts and gaskets and wash them in hot, hand-dishwashing compound solution. Then rinse and sanitize the parts in water at 170 degrees Fahrenheit or greater. After you have washed the gaskets from the food container, put them back on the container with the flat sides down and let them dry that way. Place the gaskets from the insert covers back on the insert covers and let them dry. If you take care of the rubber gaskets properly, they will not warp or lose their shape.

### Ordering Replacement Parts

If components of the insulated food container become unserviceable or are misplaced, you can order replacements through normal supply channels. Figure 9-12 gives the NSN and nomenclature for each part.

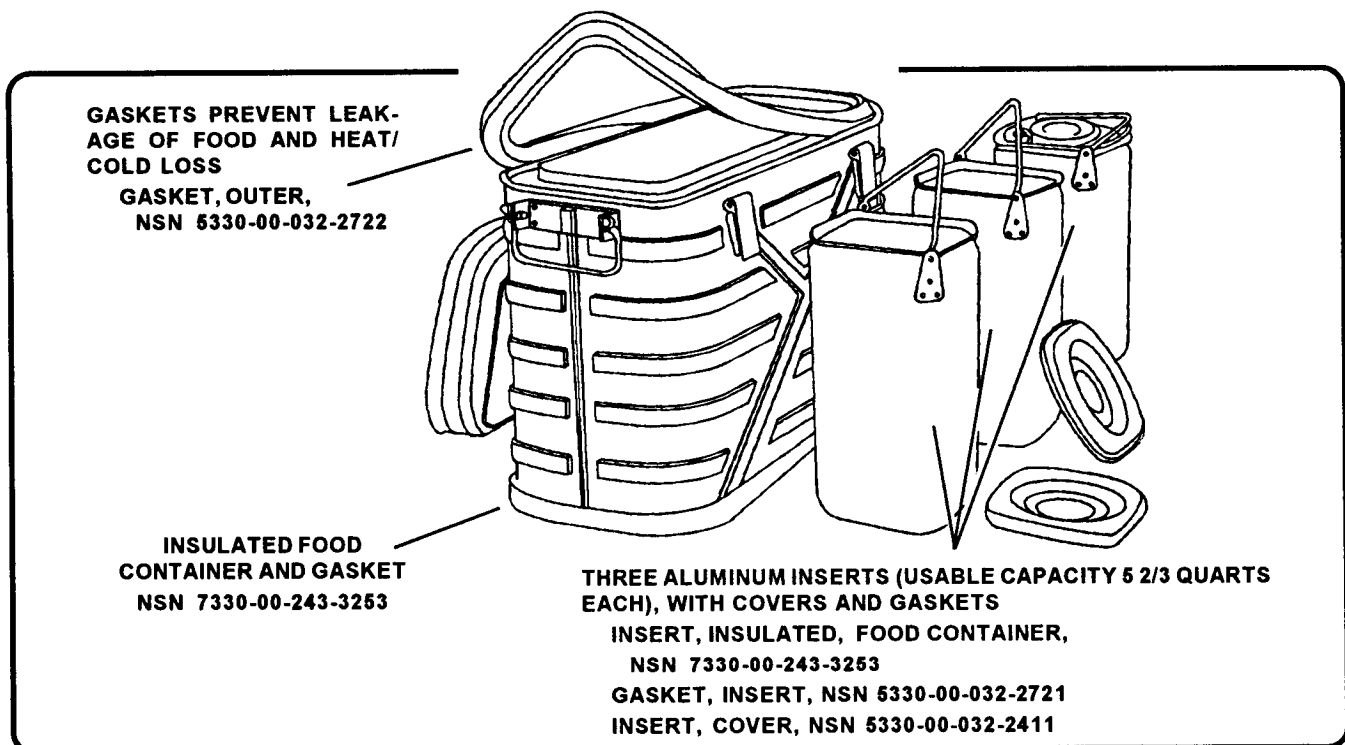

Figure 9-12. Replacement parts for the insulated food container

### Storing the Container

Store containers with lids closed but unlatched. Make sure the food container lid is pushed back slightly to allow air to circulate. This will reduce mold or mildew.

### WATER-STERILIZING BAGS

Water sterilizing bags (Figure 9-13) are used to dispense treated drinking water in field kitchens. These 36-gallon canvas bags are authorized at the rate of one for each 100 people at the field kitchen. Treated water to fill the bags is brought to the area in water trailers, tank trucks, or water cans. Direct personnel to set up and fill the bags as described below.

#### Select an Area to Set Up the Bags

The area should be readily accessible to the users. It should have good drainage and overhead protection. If you have only one bag, locate it in the bivouac area.

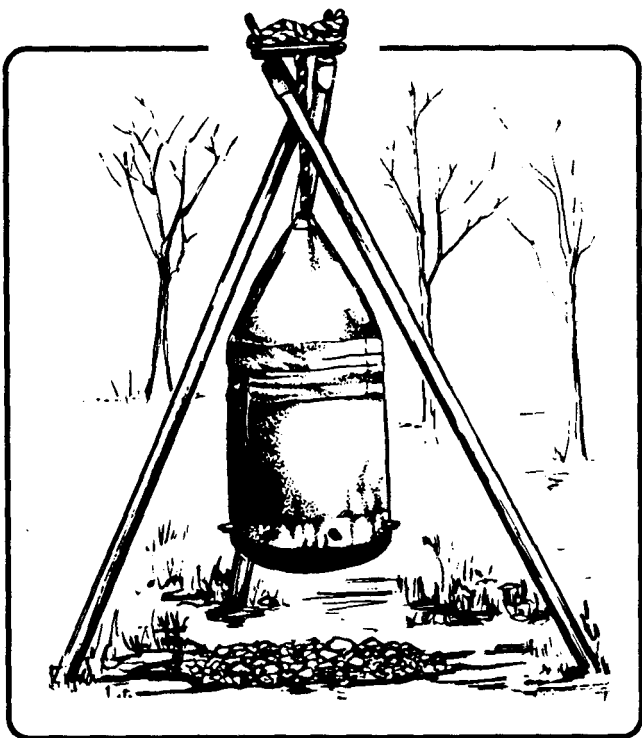

Figure 9-13. Water-sterilizing bag

### Set Up the Bags

The bags can be hung from a tree limb or from a tripod. (To build a tripod, lash three poles together as shown in Figure 9-14.) Dig a sump pit under the bag and fill the pit with gravel or stones.

### Filling the Bags

Untie each bag and lift its cover. Inspect the bag for cleanliness. If it is dirty, clean and sanitize it with food service disinfectant. Fill the bag only with potable water. Check the spigots for leaks and tighten them if necessary. Replace the cover and secure it tightly. Finally, check the water for chlorine.

### Cleaning the Bags

Scrub the inside of the bag with a chlorine solution. Use a one-half mess kit spoonful or 1 MRE spoonful of calcium hypochlorite, NSN 6810-00-255-0471, stirred into 1 gallon of water. Rinse the bag several times with clean, fresh water to get rid of all the cleaning solution. Hang it up until it is completely dry.

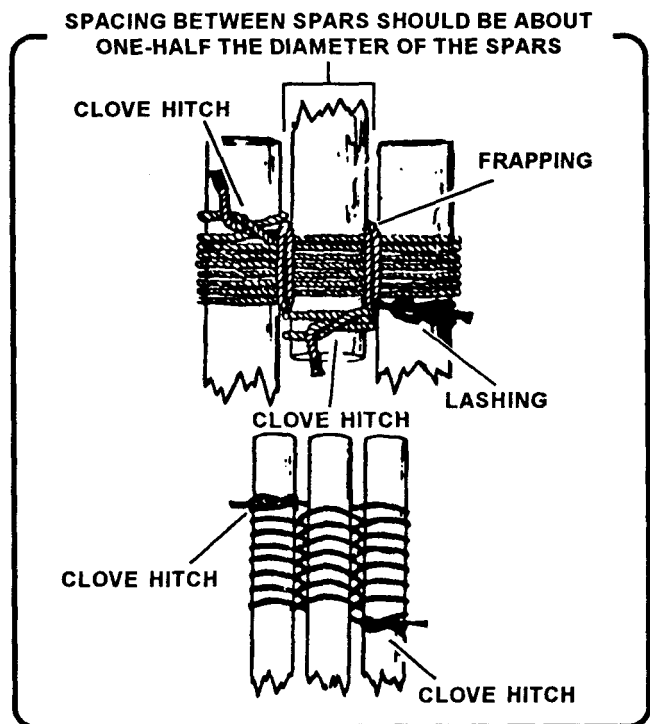

Figure 9-14. Lashing for a tripod

### Storing the Bags

Fold the dry bag and wrap it in kraft paper (NSN 8135-00-160-7752). Store it in a new fiberboard box in a clean dry place. The NSN for the fiberboard box is 8115-00-428-4124. They are packed ten to a box and are 24 by 24 by 10 inches.

### ICE STORAGE CHEST

There are two ice storage chests authorized for use in the field. They are NSN 4110-00-142-2445 (200-pound-capacity) used with the KCLFF and NSN 4110-00-640-1941 (400-pound-capacity). Store perishables in the ice chest for up to 24 hours when there is no refrigeration. When block ice and perishables are stored in the chest, use enough ice to keep the temperature below 50 degrees Fahrenheit. Potable ice that has been used to chill perishables must not be used to chill drinks, except in emergencies. When it is necessary to use ice in a drink, make sure the perishables are packed in clean, moisture-proof wrappers so they do not contaminate the ice. Also, rinse the ice with potable water before adding it to drinks. Clean the chests and gaskets with a mild detergent and warm water. Rinse the ice chest with clean water and let it air dry with the top open.

### GASOLINE LANTERN

Supported units may be able to provide the field kitchen with light sets and generators. However, that depends on the type of unit being supported. The primary source of artificial light for the field kitchen is the gasoline lantern (NSN 6260-00-170-0430). See Appendix A for a full description of the lantern.

### KCLFF-E USE

The KCLFF-E was designed to provide commanders a limited ability to prepare and serve hot meals to soldiers at forward sites. It requires two people to load, unload, prepare, and serve meals. The cooks must be provided additional support (KP) from the unit when preparing A- or B-Ration meals.

### Transport

A HMMWV and cargo trailer are provided to transport the KCLFF-E for infantry, armor, and field artillery companies or batteries of all divisional units and separate infantry brigades and armored cavalry regiments. The company load of operational rations, camouflage nets, and other items to support the KCLFF-E must be transported on other company vehicles.

### Shelter

Appropriate shelter must be provided for the KCLFF-E during inclement weather. If no shelter is available, serve MREs. If units require shelter, tentage is a CTA item. However, transportation assets are critical in the light divisions and tents may not be transportable. Examples of shelters which are currently in the system and may be ordered for use with the KCLFF-E are the—

- Tent, command post, complete, NSN 8340-00-254-5358.
- Tent, hexagonal, M1950, OD, NSN 8340-00-269-1372.
- Tent, SICP, NSN 5410-01-323-2454.

### Basic Components and Accessories

The KCLFF-E is equipped with an M-59 field range, insulated food containers, ice storage chest, beverage dispensers, a heater cabinet, M-2 burner units, work tables and required pots, cradles and utensils. The components of the KCLFF-E are listed in Table 9-1, page 9-12. The accessory equipment used with the KCLFF-E is listed in Table 9-2, page 9-12. The accessory outfit for the KCLFF-E is shown in Figure 9-15, page 9-13. The dispenser, liquid, insulated, with spare parts and their NSNs is shown in Figure 9-16, page 9-14.

**Water capability.** The KCLFF-E comes with eight 5-gallon water cans. The total capacity of the system may be expanded to approximately 111 gallons. The sixteen insulated food containers will hold 36 gallons; the eight 5-gallon water cans will

hold 40 gallons; the 15-gallon pot will hold 10 gallons; the 10-gallon pot will hold 5 gallons; and the four 5-gallon beverage dispensers will hold 20 gallons. Use of the insulated food containers and pots to transport water will require reconfiguration

of the load plan. The pots must be used with the splash lids in place.

**Storage.** All accessories can be stored in the KCLFF-E heater and other KCLFF-E components for loading and transporting purposes.

Table 9-1. KCLFF-Enhanced Equipment List (LIN K28601) (NSN 7360-01-200-9828)

ITEM	NSN	PER KCLFF-E
Dispenser, liquid, insulated	7320-01-093-7371	4
Burner Unit, M2/M2A	7330-00-842-9247	3
Cooking Pot, 10 gal, w cover	7330-00-292-2306	1
Cooking Pot, 15 gal, w cover	7330-00-292-2307	1
Heater Cabinet		1
Insulated Food Container w inserts	7330-00-238-2411	12
Pot Cradle Assembly		1
Table, work and serving		2
Lifter, tray pack, extracting	7330-01-234-2164	1
Lifter, tray pack, serving	7330-01-224-0914	1
M59 Field Range		1
Ice Storage Chest (200 lb)		1

Table 9-2. Basic issue accessory items for the KCLFF-E

NSN	DESCRIPTION	U/M	QTY
8030-00-087-8630	Antiseize compound	EA	1
4610-00-268-9890	Bag, water, sterilizing	EA	1
7330-00-078-5706	Board, food, cutting	EA	1
7920-00-291-5815	Brush, wire	EA	1
8110-00-824-1443	Can, friction, top	EA	1
7240-00-222-3086	Can, gasoline (5 gal)	EA	2
7330-01-245-0201	Can opener, hand	EA	2
7330-00-272-2591	Can opener, tray pack	EA	1
7240-00-089-3827	Can, water (5 gal)	EA	8
5120-00-379-2490	Cleaner, burner, slot	EA	1
4210-00-270-4512	Fire extinguisher	EA	1
	First aid kit	EA	1

Table 9-2. Basic issue accessory items for the KCLFF-E (continued)

NSN	DESCRIPTION	U/M	QTY
7310-00-999-2552	Generator, preheater	EA	4
8415-01-134-8233	Gloves, heat protective	EA	1
	Hose, drain	EA	1
4720-00-379-2518	Hose, pump, inflating	EA	1
7340-00-197-1271	Knife, boning	EA	1
7340-00-223-7766	Knife, bread	EA	1
6260-00-170-0430	Lantern, gasoline	EA	1
7330-01-234-2164	Lifter, tray pack, ext	EA	1
7330-01-224-0914	Lifter, tray pack, serv	EA	1
7240-00-205-3096	Measure, liquid (2 qt)	EA	1
7240-00-171-6154	Nozzle, spout, can, gas	EA	1
7330-00-292-2306	Pot, stock (10 gal)	EA	1
7330-00-292-2307	Pot, stock (15 gal)	EA	1
4320-00-852-9036	Pump, inflating	EA	1
5120-00-222-8852	Screwdriver, flat	EA	1
7340-00-223-7800	Spoon, basting	EA	1
7340-00-205-1421	Spoon, serving, slotted	EA	1
	Tray pack, cover	EA	TBD
7310-00-310-8544	Tool chest	EA	1
5120-00-240-5328	Wrench, adj, crescent	EA	1
5120-00-303-7737	Wrench, combination	EA	1

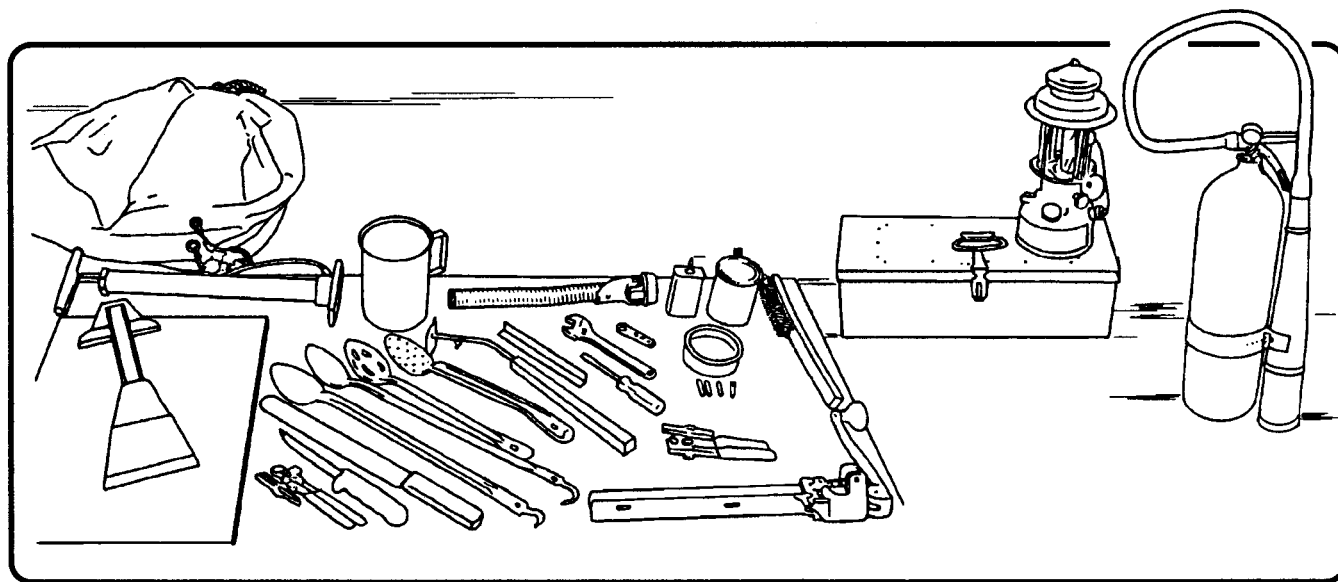

Figure 9-15. Accessory outfit for the KCLFF-E

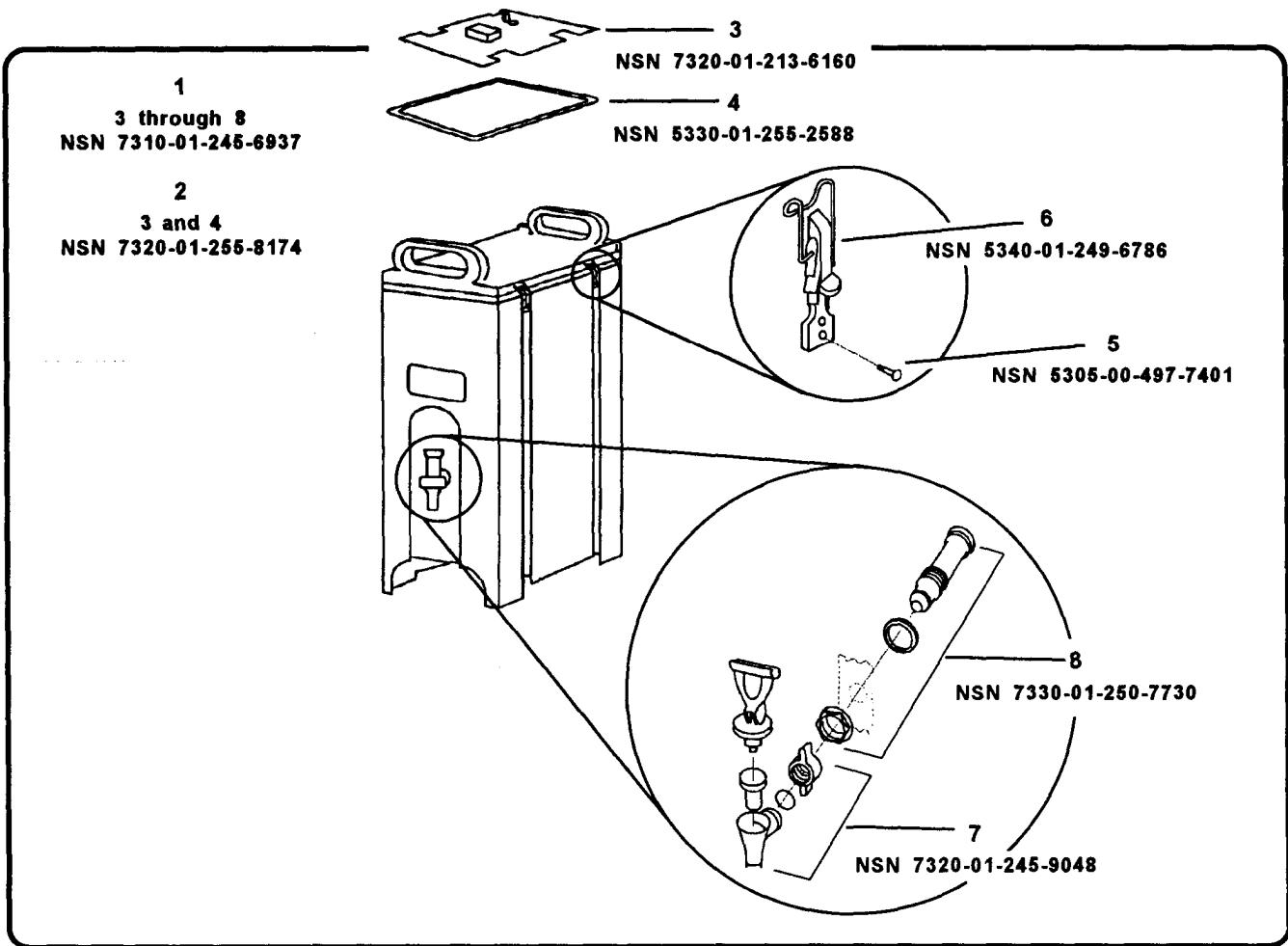

Figure 9-16. Dispenser liquid, insulated

**Tray pack lifter, extracting.** The tray pack lifter, extracting, (Figure 9-17) is the long-handled utensil used to remove tray packs from the hot water.

**Tray pack lifter, serving.** The tray pack lifter, serving, (Figure 9-17) is the utensil which clamps on either side of the tray pack. This utensil is used to move a hot tray pack, once it has been opened, to the serving line.

**Hot pads.** Once a tray pack has been removed from the hot water using the tray pack lifter, extracting, the hot tray packs can be handled with hot pads. The hot pads should be used to transfer the hot tray packs into the insulated food containers. The hot pads should not be used alone to handle opened tray packs.

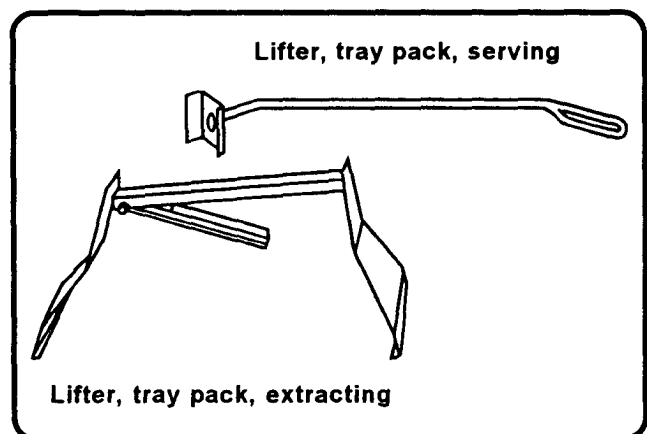

Figure 9-17. Lifter, tray pack, extracting and lifter, tray pack, serving

## Site Selection

All personnel working with the KCLFF-E should be familiar with the procedures in TM 10-7360-209-13P. Although the KCLFF-E goes where necessary, consider the following points when selecting a site for setting up the KCLFF-E:

- Good natural cover is ideal to shield troops from the enemy and to protect them from sun, heat, and cold winds.
- High, dry ground near a protected slope is ideal to ensure good drainage and to protect you from the wind.
- Enough space to keep from crowding the troops is required. It also allows you to spread out your equipment enough to work efficiently.
- It is ideal if you are near a source of potable water.

- Sandy loam or gravelly soil is best to let excess water seep away and to help soakage pits and trenches work well.

## Camouflaging

The KCLFF-E must be camouflaged after it is set up. Follow the points on page 5-28 when you camouflag the KCLFF-E, equipment, and the feeding site.

## Operation

When setting up the KCLFF-E, precautions must be taken to ensure safe operation. Before operating the KCLFF-E, ensure personnel follow the procedures in Figure 9-18.

1. Locate the tray pack heater in a reasonably level and clear area.
2. Erect the two serving tables within 5 to 6 feet of the tray pack heater.
3. Place a fire extinguisher conveniently near the heater.
4. Fill the heater with 20 gallons of water (about 8 inches deep).
5. Follow all precautions and instructions in TM 10-7360-204-13&P to light the M2 burner unit. Monitor the burner for proper flame color.
6. When the flame is properly adjusted (has reached a stable operating state), carefully slide the unit in the burner rack under the heater tank. **DO NOT FORCE IT.**
7. While the water is being heated, ready the tray packs for loading. The tray packs are loaded *after* the water begins to boil.
8. Mount the can opener on the serving table.
9. Place eating and serving utensils, trays, bread, and condiments in a convenient place on one of the serving tables.
10. If a hot beverage is to be served, assemble a 15-gallon stock pot, cradle, and burner rack.
11. When the water in the heater has started to boil, load a maximum of 24 tray packs into the tank as follows:
  - Arrange the tray on their edge in two rows of 11 with two trays between the rows.
  - Place the first tray in the tank with the bottom of the tray against the side of the tank and the short side down. Load entree tray packs requiring the full amount of heating time and others progressively so the full menu may be served together.
  - Close the cover on the tank.
  - Periodically monitor the pressure gauge on the burner while the trays are being heated.

*Figure 9-18. Safety precautions for operating the KCLFF-E*

12. After 45 minutes, the trays should have reached the serving temperature. (Some items, such as vegetables, may take only 15 minutes to heat).
13. If the trays are not served immediately, or if they are to be taken to a remote site, take them from the heater and put them into insulated food containers to maintain the serving temperature.
14. To load the insulated food container, remove the tray packs from the heater cabinet using the tray pack lifter, extracting.
15. Transfer the tray pack using hot pads. Place the tray packs into the insulated food container. Soldiers must use the tray pack lifter, serving to place opened tray packs on the serving line.
16. Load utensils and condiments into a box and close the box.
17. Use the hot water in the tray pack heater and stock pots for sanitation purposes. Add one-half cup of dishwashing compound (hand) for each 5 gallons of water to the T-Ration heater. (If the alternate method is used, add one-half of a packet of food service disinfectant for each 5 gallons of unheated water in the remaining stock pot). Clean the utensils, tables, insulated food containers and beverage dispensers using the water in the heater cabinet for washing and the stock pots for rinsing.
18. After the unit has cooled, drain the water from the tank by opening the drain valve on the bottom of the unit. The drain hose should be attached so that the cooking area does not get muddy. Run the drain hose into a soakage pit to prevent standing water that could breed insects. When the water is contaminated with foodstuff and/or other waste, dumping must be according to local environmental regulatory requirements. Never dump contaminated water directly on top of the ground.

*Figure 9-18. Safety precautions for operating the KCLFF-E (continued)*

### Serving Operations

The cook operating the KCLFF-E will require servers to assist at meal time. Two to three servers could be used, depending on the number of troops to be fed. Examples of how to use servers follows.

- One server would serve the entree, starch, and vegetable.
- One server would serve the salad, bread, and dessert.
- One server would serve the beverages (server fills cups) and condiments.

When serving operations are ongoing, the cook must replenish the serving line, open tray packs, monitor serving sizes, and refill beverage dispensers,

Before serving, the cook is responsible for briefing the servers on proper serving sizes and portion control. During serving, it is important that the cook monitor the servers to ensure that the serving procedures and portion sizes are correct.

The cook is also responsible for disposing of leftovers (serve or discard) and for using insulated food containers and beverage dispensers for remote site feeding.

### Planning and Accounting Procedures

No operation can be totally successful without proper planning. The operation of the KCLFF-E is no exception to the rule.

Each tray pack contains either 9 or 18 portions. Therefore, there is no general rule to determine the number of modules required to feed a certain number of soldiers. The FOS will have to determine the number of modules to send to remote sites.

Complete planning instructions for the T-Ration are in Chapter 5.