

CHAPTER 19

LAUNCHING BY SINGLE GIRDERS

It may be advisable to launch a panel bridge one girder at a time. This method is advantageous when launching from an existing bridge where piers are wide enough to take the ends of a new span, but the existing bridge is not wide enough to launch the new span complete. Such launching is recommended when there is—

- An existing through-type panel bridge (Figure 19-1).
- An existing through-type civilian bridge where the width between side walls or trusses is less than 20 feet 8 ½ inches (6.32 meters) (Figure 19-2).
- An existing deck-type bridge where width of deck is less than 20 feet 8 ½ inches (6.32 meters) (Figure 19-2).

- A launching of span of panel bridge to a point much lower or of varying height, as to intermediate landing bay of a floating bridge in tidal water (Figure 19-3).

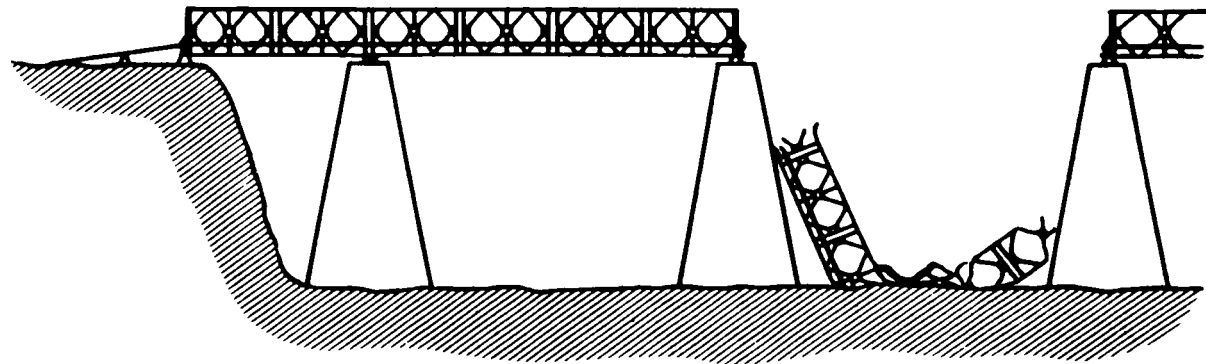

Figure 19-1 **Damaged span of multispan panel bridge** (piers are wide enough to take ends of new span but existing bridge is not wide enough to launch new span complete)

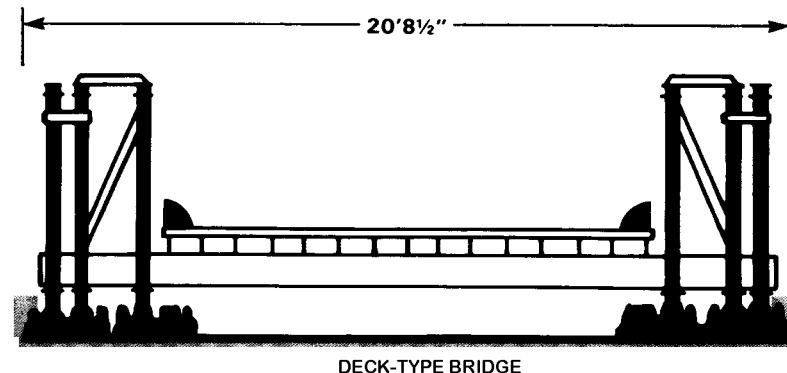
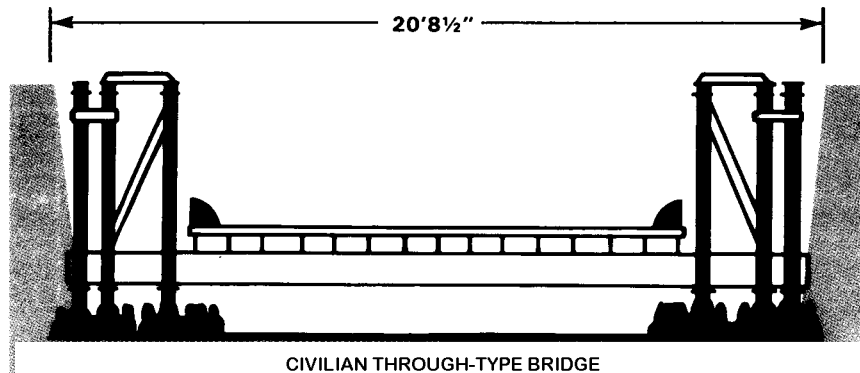
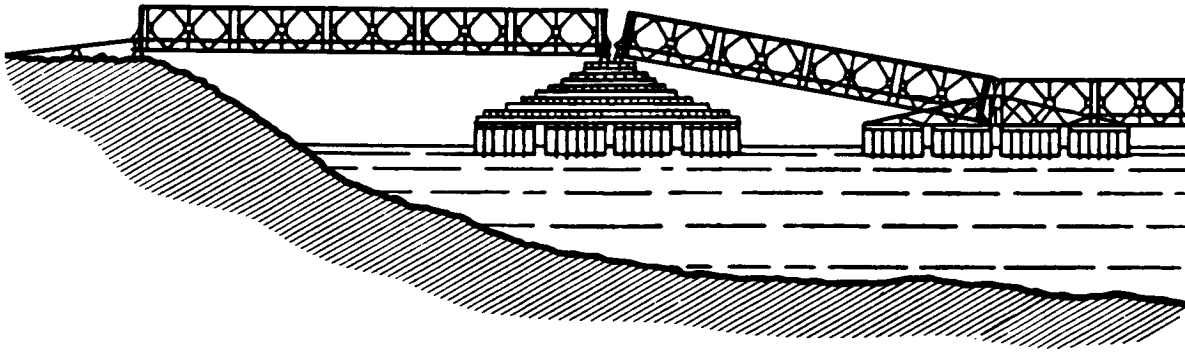

Figure 19-2 **Necessary clearances for launching panel bridge from existing bridge**



*Figure 19-3 Intermediate landing bay of floating panel bridge in tidal water*

### TYPES OF GIRDERS

A single girder may be made up of a single truss or of two or more trusses connected by bracing frames and tie plates. Five trusses are the maximum number that can be handled practicably. Figure 19-4 (page 246) shows girders with various combinations of two to five trusses. Single, double-, and triple-truss girders are used for through-type panel bridges. Any of the girders may be used for a deck-type panel bridge.

To save launching time, the wider girders are preferred to many narrow bridges. Four- and five-truss girders usually are used for multilane deck-type bridges.

### Assembly sequence

The assembly sequence for launching by single girders is as follows:

- 1 Assemble girder on deck of existing bridges and then launch over gap.
- 2 Lower or slide it into position and then launch next girder.

- 3 To complete the bridge, add standard sway braces, transoms, stringers, and decking, or expedient bracing and flooring.

### Methods of launching

Single-truss girders may be launched with gin poles or high line. Multitruss girders may be launched by any one of the following methods:

- Counterweight.
- Launching nose.
- Gin pole and snubbing tackle.
- High line.

### Working parties

The size of working parties varies with size of girder. To assemble girders, divide soldiers into panel parties, pin parties, and bracing parties. Combine them to launch the girders. After the girders are in place, divide the soldiers into bracing and decking parties to complete the bridge.

### Limitations

There are limitations of this kind of launching. Launching by single girders takes longer than the normal method of launching panel bridges.

A girder is always launched as a single-story girder; other trusses or stones are added after the girder has been launched. Bracing frames between trusses prevent overturning and give the girder rigidity. (However, when launching long girders in the wind with counterweight or launching nose, the end is subject to considerable whipping.) And plain rollers must be placed under every truss to support the girder evenly and prevent twisting.

### LAYOUT OF ROLLERS

Plain rollers are used in sets under the girder, so each truss rests on a roller. In some cases, plain rollers must be staggered to prevent interference between rollers. Figure 19-4 shows the arrangement of plain rollers in sets under the girder.

Rocking rollers cannot be staggered. When trusses are spaced 1 foot 6 inches (5.3 centimeters) on center, rocking rollers are placed under every truss. The two outer trusses are spaced 8½ inches (21.6 centimeters) on centers by tie plates and a single rocking roller is placed under the inner of the two trusses (Figure 19-5, page 247). Remove the outer guide roller. Wedge shims between tie plate and chord-channel flanges to prevent outside truss from slipping down. Under the four-truss (2-foot 2½-inch) (67.4 centimeter) girder, the rocking rollers are placed under the outer trusses (Figure 19-6, page 247).

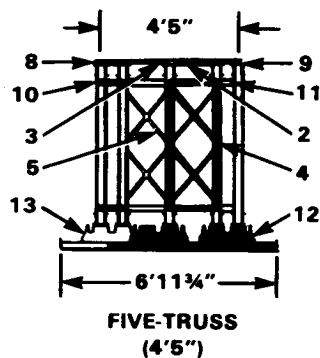
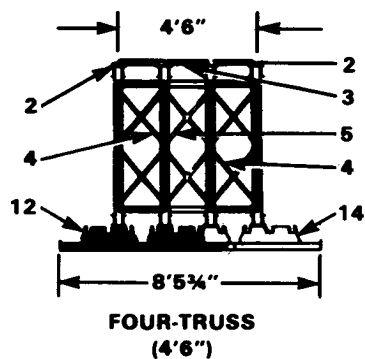
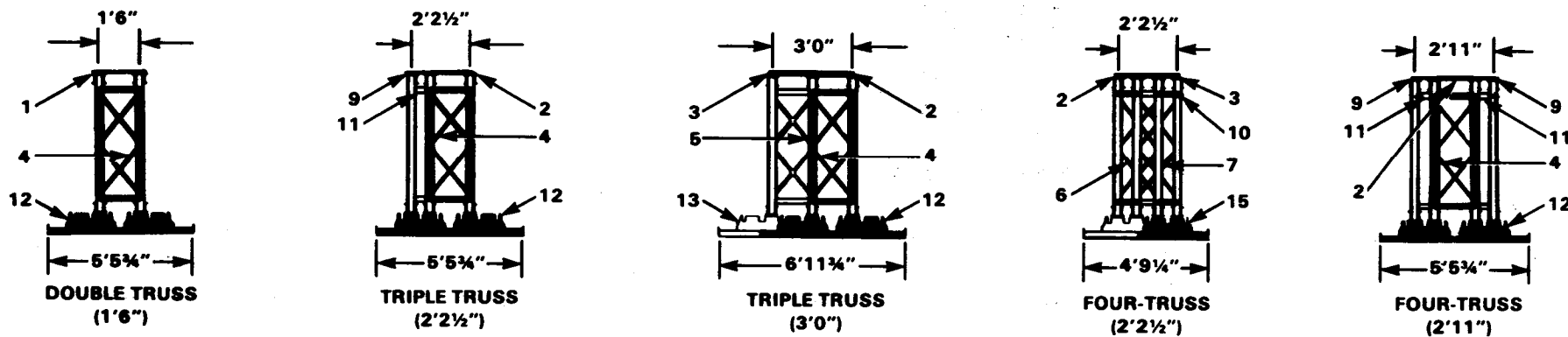

**BRACING FRAMES**

- 1 ON TOP OF PANEL
- 2 ON TOP OF EVEN-NUMBERED PANELS
- 3 ON TOP OF ODD-NUMBERED PANELS
- 4 ON FRONT END OF EVERY PANEL
- 5 ON BACK END OF EVERY PANEL
- 6 ON BACK END OF EVEN-NUMBERED PANELS
- 7 ON BACK END OF ODD-NUMBERED PANELS

**TIE PLATES**

- 8 ON TOP OF EVEN-NUMBERED PANELS
- 9 ON TOP OF ODD-NUMBERED PANELS
- 10 ON FRONT END OF EVERY PANEL
- 11 ON BACK END OF EVERY PANEL

**PLAIN ROLLERS**

- 12 TWO ROLLERS ON TEMPLATES PLACED BACK TO BACK
- 13 THIRD ROLLER AND TEMPLATE BEHIND FIRST PAIR OF ROLLERS
- 14 SECOND PAIR OF ROLLERS AND TEMPLATES BEHIND FIRST PAIR
- 15 TWO ROLLERS ON TEMPLATES STAGGERED ONE BEHIND THE OTHER

Figure 19-4 Multitruess girders and arrangement of plain rollers for launching

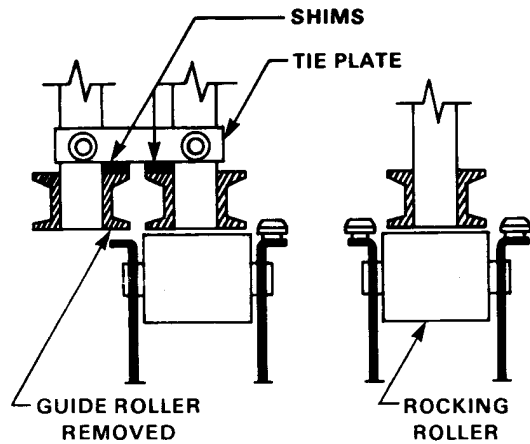

Figure 19-5 Arrangement of rocking rollers under a triple-truss girder

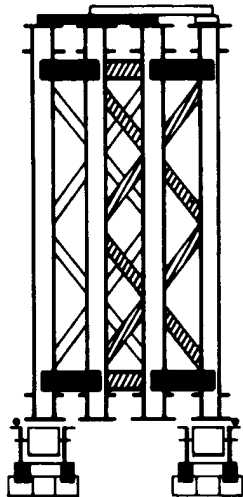

Figure 19-6 Arrangement of rocking rollers under a four-truss girder

The procedure for laying out sets is—

- Use rocking rollers at the edge of the gap and place plain rollers at about 25-foot (7.6-meter) intervals back along the girder (Figure 19-7, page 248). With double-truss girders, plain rollers can be used instead of rocking rollers at the edge of the gap.
- When using a counterweight (Figure 19-8, page 249) or launching nose (Figure 19-9, page 250), assemble and launch the girder on the side of the existing bridge nearest its final position. Assemble a second girder simultaneously at the other side of the deck of the existing bridge. Lay out rollers accordingly.
- When using a gin pole and snubbing tackle, two gin poles, or a high line, lay out the rollers so as to assemble and launch the girder along the centerline of the bridge.
- When launching from an existing panel bridge, place all plain rollers directly over transoms to avoid overstressing stringers (Figure 19-7). Set rocking rollers preferably on cribbing directly on the pier. If it is necessary to place the rocking rollers on the deck of the existing panel bridge, place them directly over the end transom. If the total launching weight on rocking

rollers is more than 14 tons (12.7 metric tons), use two transoms under the rollers; if the launching weight is more than 28 tons (25.5 metric tons), wedge the cribbing under the center of the end transoms.

**ASSEMBLY OF GIRDERS**

The girder may have from two to five trusses (Figure 13-10).

Connect trusses of multitruss girders at every possible place by bracing frames and tie plates across the top chords and ends of panels. All tie-plate bolts must be tight and shims must be used to prevent the outer truss from slipping down when the end of the girder is over the gap (Figure 19-5). In girders with outer trusses spaced 8 ½ inches (21.6 centimeters), insert panel pins connecting the nose to the main girder from the inside so the nose can be disconnected after launching. In both the main girder and the nose, always insert the pins from the outside toward the centerline of the girder.

Place end posts on the front end of all trusses before launching, except when using a launching nose, in which case place the front end posts after the girder has been launched. Place the rear-end posts when the girder is in position for jacking down. Table 19-1 (page 250) lists the parts required to assemble each type of girder.

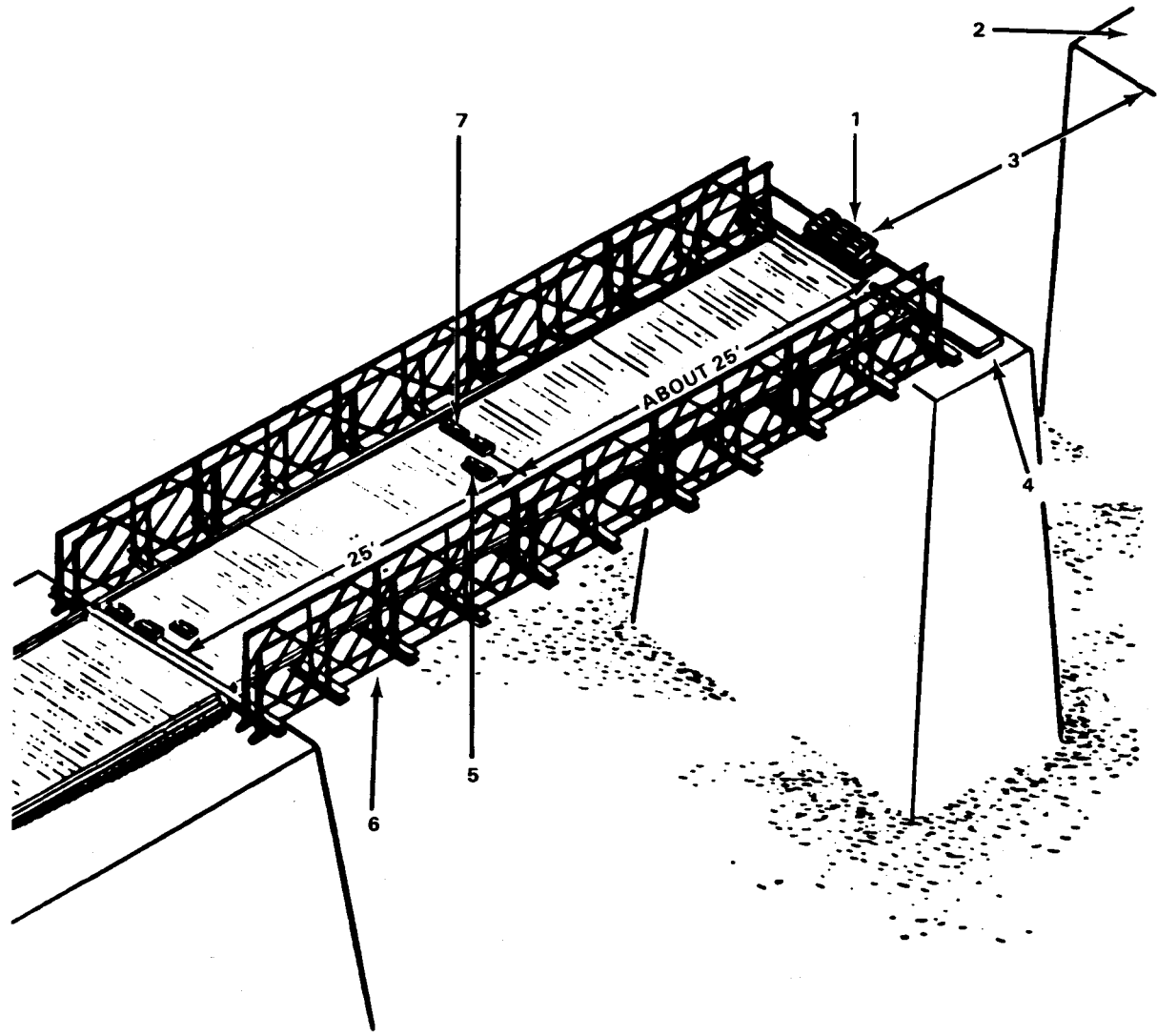

- 1 ROCKING ROLLERS
- 2 PIER
- 3 GAP
- 4 SKIDDING BEAM
- 5 THIRD ROLLER STAGGERED
- 6 EXISTING BRIDGE
- 7 ROLLER PLACED DIRECTLY OVER TRANSOM

Figure 19-7 Layout of launching rollers for launching a triple-truss girder from existing panel bridge

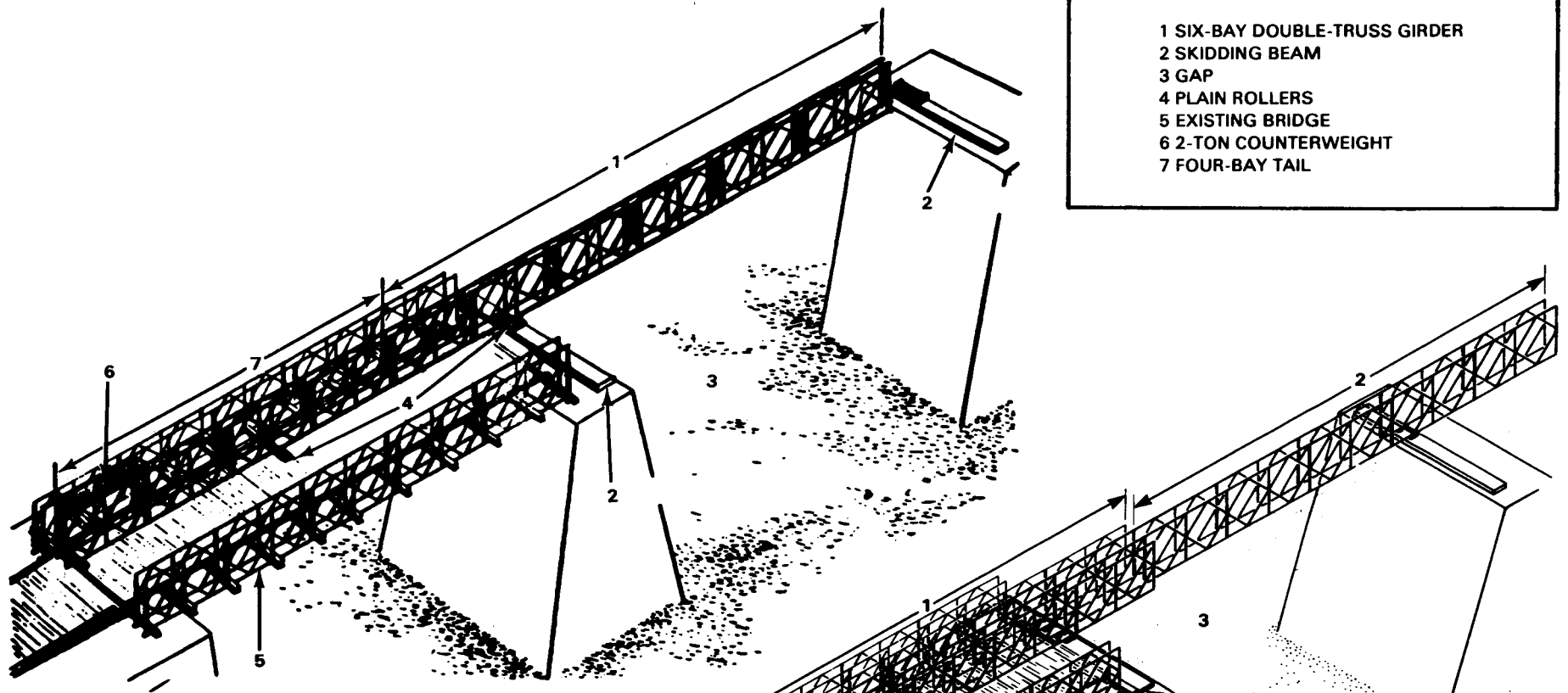

- 1 SIX-BAY DOUBLE-TRUSS GIRDER
- 2 SKIDDING BEAM
- 3 GAP
- 4 PLAIN ROLLERS
- 5 EXISTING BRIDGE
- 6 2-TON COUNTERWEIGHT
- 7 FOUR-BAY TAIL

*Figure 19-8 Launching a single girder with a counterweight*

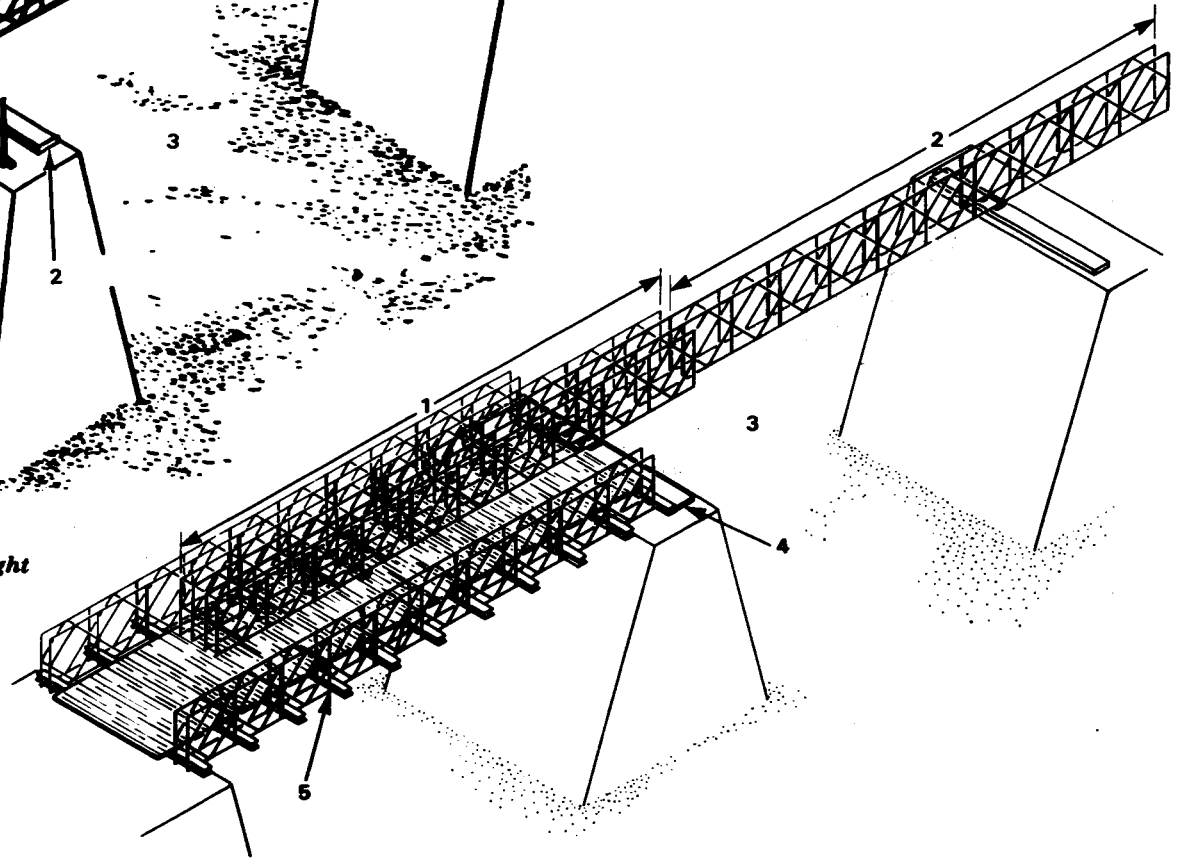

- 1 SIX-BAY FOUR-TRUSS GIRDER (2'11")
- 2 FIVE-BAY DOUBLE-TRUSS LAUNCHING NOSE
- 3 GAP
- 4 SKIDDING BEAM
- 5 EXISTING BRIDGE

*Figure 19-9 Launching a four-truss girder with a launching nose*

### LAUNCHING OF GIRDERS

There are several methods of launching by single girders. These are the counterweight, launching-nose, gin-pole and snubbing-tackle, direct-lift, and high-line methods.

#### Counterweight method

Launch a single girder by counterweight as follows:

- Add the counterweight to the rear end of the girder to balance the front end of the girder as it is pushed on rollers out over the gap. Long girders may be kept in line by using side guys and a pull winch from the far pier. When across the gap, the front end lands on rollers at the far bank or pier, or on landing-bay pier of a floating bridge. Then disconnect the counterweight, attach the rear end posts, remove the rollers at each end, and jack down the girder onto a skidding beam.
- Girders may be counterweighted either by adding weights to the last bay of a short tail on the girder or by making the girder of the same assembly and twice as long as the span so the tail alone will counterbalance the span. Table 19-2 lists weights needed on short tails to counterweight various spans of multitruss girders. (Longer spans cannot be launched by this method because of insufficient lateral stability.) If the long tail is used, it may be disconnected after the first girder is launched, and used for a second girder.

Table 19-1 Parts required to assemble single-truss and multitruss girders

ITEM	NUMBER OF PARTS PER TWO BAYS								
	TRUSSES								
	ONE	TWO	THREE	THREE	FOUR	FOUR	FIVE		
	SPACING OF OUTER TRUSSES								
		1'6"	2'2½"	3'0"	2'2½"	2'11"	4'6"	4'5"	
Bolt, bracing		16 <sup>2</sup>	24	24	32 <sup>4</sup>	36	36 <sup>2</sup>	48	
Frame, bracing		4 <sup>2</sup>	3 <sup>3</sup>	6	4 <sup>4</sup>	3 <sup>3</sup>	9 <sup>2</sup>	6	
Panel	2	4	6	6	8	8	8	10	
Pin, panel <sup>1</sup>	4	8	12	12	16	16	16	20	
Plate, tie			6		8	12		12	
Post, end									
				ADD ONE END POST AT EACH END OF EACH TRUSS					

<sup>1</sup>Add two panel pins at end of each truss  
<sup>2</sup>Add one bracing frame and four bracing bolts in last bay  
<sup>3</sup>Add one bracing frame in last bay  
<sup>4</sup>Delete one bracing frame and four bracing bolts from last bay

The counterweight method is useful when site conditions at the far side prevent use, removal, or disposal of a launching nose, or erection of a gin pole or high line. When launching long girders of a deck-type bridge, a counterweight permits tipping the far end directly onto the pier without jacking down.

#### Launching-nose method

Launch a single girder by the launching-nose method as follows:

- Attach a lightweight launching nose to the front end of the girder, and push the girder with nose on rollers out over the gap. To compensate for sag, launching-nose links may be used in the same manner as when launching the normal

panel bridge. Long girders may be kept in line by using side guys and a pull winch. When across the gap, the nose lands on rollers on the far bank. Then disconnect nose, attach front end posts, remove rollers at each end, and jack down the girder onto skidding beams.

- Table 19-3 (page 253) lists the types and lengths of noses needed to launch multi-truss girders. Single-truss girders cannot be launched by this method. Brace launching noses the same as the girder. When launching the triple-truss girder with an eccentric double-truss nose, the nose must be dismantled bay by bay as it passes over the landing rollers. Otherwise, the nose beyond the landing rollers twists the girder, and may cause failure.

- The launching-nose method is used for longer girders, where sag is appreciable. It can also be used for girders too heavy for a gin pole or high line. Launching by this method is easier than with a counterweight, because the girder with nose is lighter than the girder with counterweight.

**Gin-pole and snubbing-tackle method**

Launch a single girder by the gin-pole and snubbing-tackle method (Figure 19-10, page 252) as follows:

- Erect a gin pole at the far bank or pier. Rig tackle from the gin pole to the front end of the girder with the fall line running to the winch of a truck on the bridge or bank. When a truck-mounted crane or tractor is used at the tail of the girder, lead the fall line around it by a snatch block at the side of the bridge. For long, heavy girders, attach guy lines near the center of the

girder on each side and control by winches on trucks to each side of bridge. The girder rides on rollers on the near bank. Brake it by snubbing tackle attached to the rear end of the girder to keep it upright and to lift it onto the bearings. Power applied to the hauling winch pulls the girder across the gap. Move a truck-mounted crane forward with the girder, keeping the snubbing line taut to prevent too rapid movement. When the girder has passed its balance point, let it dip about one-tenth of its length to lessen stress in

*Table 19-2 Required counterweight for various spans of multitruss girders*

SPAN (ft)		40	50	60	70	80	90
<b>DOUBLE-TRUSS GIRDER AND TAIL</b>	Bays in tail	3	3	4	4	5	5
	Counterweight (tons)	1.1	2.3	2.0	3.5	3.0	4.2
	Total weight on rocking rollers (tons)	5.6	7.5	8.6	10.4	11.4	13.3
<b>TRIPLE-TRUSS GIRDER AND TAIL WITH OUTER TRUSSES SPACED 2'2½"</b>	Bays in tail	3	3	4	4	5	5
	Counterweight (tons)	1.6	3.3	2.9	4.8	4.4	6.2
	Total weight on rocking rollers (tons)	8.3	10.9	12.4	15.1	16.5	19.3
<b>TRIPLE-TRUSS GIRDER AND TAIL WITH OUTER TRUSSES SPACED 3'0"</b>	Bays in tail	3	3	4	4	5	5
	Counterweight (tons)	1.7	3.5	3.0	4.9	4.4	6.3
	Total weight on rocking rollers (tons)	8.5	11.3	12.7	15.6	17.0	19.9
<b>FOUR-TRUSS GIRDER AND TAIL WITH OUTER TRUSSES SPACED 2'2½"</b>	Bays in tail	3	3	4	4	5	5
	Counterweight (tons)	2.1	4.5	3.9	6.4	5.9	8.2
	Total weight on rocking rollers (tons)	11.0	14.7	16.5	20.3	22.2	25.8
<b>FOUR-TRUSS GIRDER AND TAIL WITH OUTER TRUSSES SPACED 2'11"</b>	Bays in tail	3	3	4	4	5	5
	Counterweight (tons)	2.1	4.4	4.0	6.3	5.8	8.2
	Total weight on rocking rollers (tons)	11.0	14.4	16.5	20.1	22.0	25.7
<b>FOUR-TRUSS GIRDER AND TAIL WITH OUTER TRUSSES SPACED 4'6"</b>	Bays in tail	3	3	4	4	5	5
	Counterweight (tons)	2.2	4.6	4.1	6.6	6.1	8.5
	Total weight on rocking rollers (tons)	11.4	15.1	17.2	21.0	23.0	26.7
<b>FIVE-TRUSS GIRDER AND TAIL</b>	Bays in tail	3	3	4	4	5	5
	Counterweight (tons)	2.7	5.6	5.0	8.0	7.4	10.3
	Total weight on rocking rollers (tons)	13.9	18.4	20.8	25.5	28.0	32.4

the tackle. After the girder is across the gap, the gin pole and truck-mounted crane lift it directly onto the bearings.

- When a truck-mounted crane is not available, two gin poles may be used, one on each bank. Attach both gin-pole lines to the front end of the girder, which is pulled over the gap by taking up on the far gin-pole line and slacking off on the near gin-pole line. When the front end of the girder is over the far bank, change the line from the near gin pole from the front to the rear of the girder. Then lower the girder onto its bearings.
- This method is better for short spans, since long girders are heavy and difficult to handle. It also saves bridge equipment, because it eliminates the need for either a launching nose or counterweight. In addition to handling girders, the gin pole and truck-mounted crane can be used to telegraph transoms and decking into place.

### Direct-lift method

Launch a single girder by the direct-lift method as follows:

- Assemble the girder on ground beside the piers. Use two cranes or gin poles to lift the girder into place on the piers. In case of a water gap, the girder may be floated out to the piers and lifted into place by cranes on rafts or on the piers. Cranes are

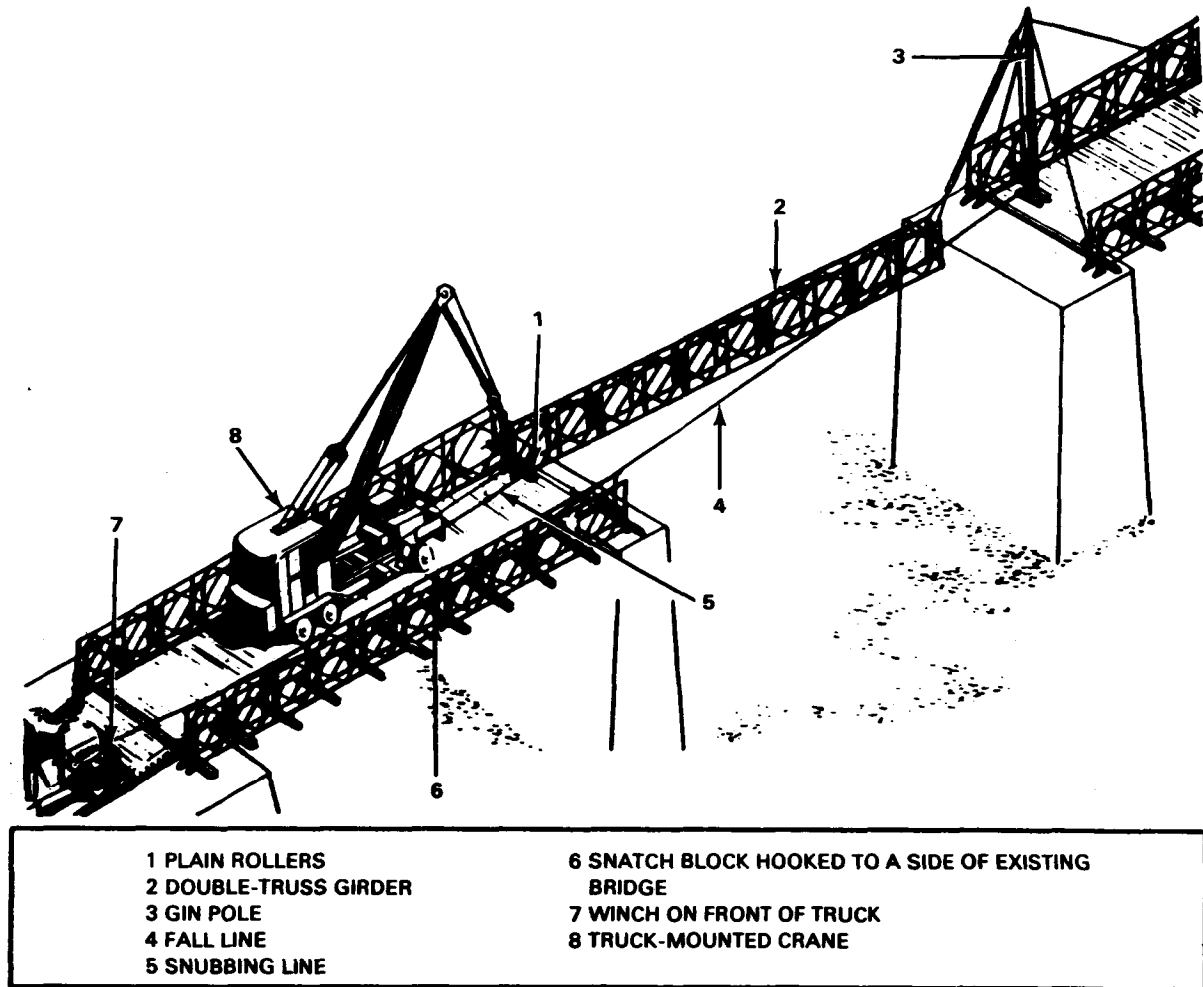

Figure 19-10 Launching a double-truss girder with a gin pole and snubbing tackle

not needed if the piers are low enough so the girder can be floated into place and lowered onto the piers by pumping water into the raft pontoons.

- The length of girder that can be launched by this method is limited by the capacity of the cranes. If the girders are short and light, a single crane can be used.

Table 19-3 Composition of launching noses and launching weights of multitruss girders

TYPE OF GIRDER	SPACING OF OUTER TRUSSES	TYPE OF NOSE	NUMBER OF BAYS IN NOSE		LAUNCHING WEIGHT IN TONS										
			SPAN (ft) <sup>1</sup>								No	Wt			
			40	50	60	70	80	90	100	110					
DOUBLE-TRUSS	1'6"	DOUBLE-TRUSS	4	5	6	7	8	9							
			5.0	6.4	7.6	8.8	10.2	11.4							
TRIPLE-TRUSS	2'2½"	DOUBLE-TRUSS <sup>2</sup>	4	5	6	6	7	8							
			6.2	7.8	9.3	10.3	11.8	13.4							
TRIPLE-TRUSS	3'0"	DOUBLE-TRUSS <sup>2</sup>	4	5	5	6	7	8							
			6.3	8.0	8.9	10.5	12.0	13.7							
TRIPLE-TRUSS	3'0"	TRIPLE-TRUSS	4	5	6	7	8	9							
			7.6	9.6	11.4	13.4	15.2	17.2							
FOUR-TRUSS	2'2½"	FOUR-TRUSS	4	5	6	7	8	9	10						
			9.9	12.4	14.8	17.3	19.8	22.3	24.8						
FOUR-TRUSS	2'11"	DOUBLE-TRUSS	3	4	5	6	6	7	8	9					
			6.8	8.6	10.6	12.4	13.6	15.5	17.4	19.2					
FOUR-TRUSS	4'6"	DOUBLE-TRUSS	3	4	5	6	6	7	8	9					
			7.0	8.9	10.9	12.8	14.1	15.9	17.9	19.8					
FIVE-TRUSS	4'5"	TRIPLE-TRUSS	4	4	5	6	7	8	8	9					
			10.0	11.6	14.1	16.6	19.2	21.6	23.2	25.7					

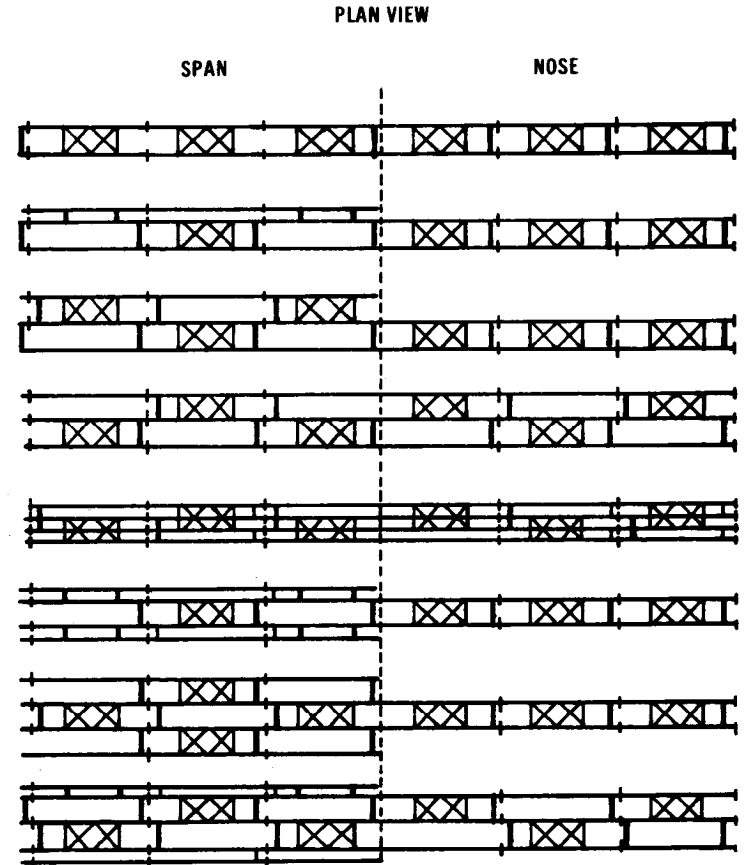

<sup>1</sup>Longer spans cannot be launched by this method because of insufficient lateral stability  
<sup>2</sup>Remove nose as each bay clears far-shore landing rollers

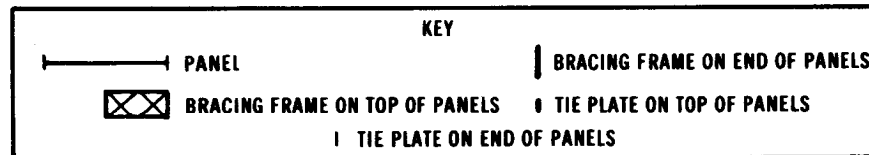

**High-line method**

Launch a single girder by the high-line method (Figure 19-11) as follows:

- Rig a high line of suitable capacity across the gap along the centerline of the bridge. Suspend the girder from the high line, pull it over the gap, and lower it onto skidding beams. Attach the trolleys on the high line to slings on the girder near the quarter points. Roll the girder on the approach span to its balance point on the first roller before it is carried by the high line. Use tag lines at both ends of the girder to control it during launching.
- This method is useful for launching deck-type bridges where the girder has to be lowered a considerable distance to the skidding beams. In addition to handling the girders, the high line can be used to carry out the transoms and decking, and where trestle-approach spans are used, it can be used to carry out bridge parts for the approach spans. This method also eliminates the need for either a launching nose or counterweight. The capacity of high lines is usually limited to short single or double-truss girders. Table 19-4 lists the weight, in tons, of various lengths of girders.

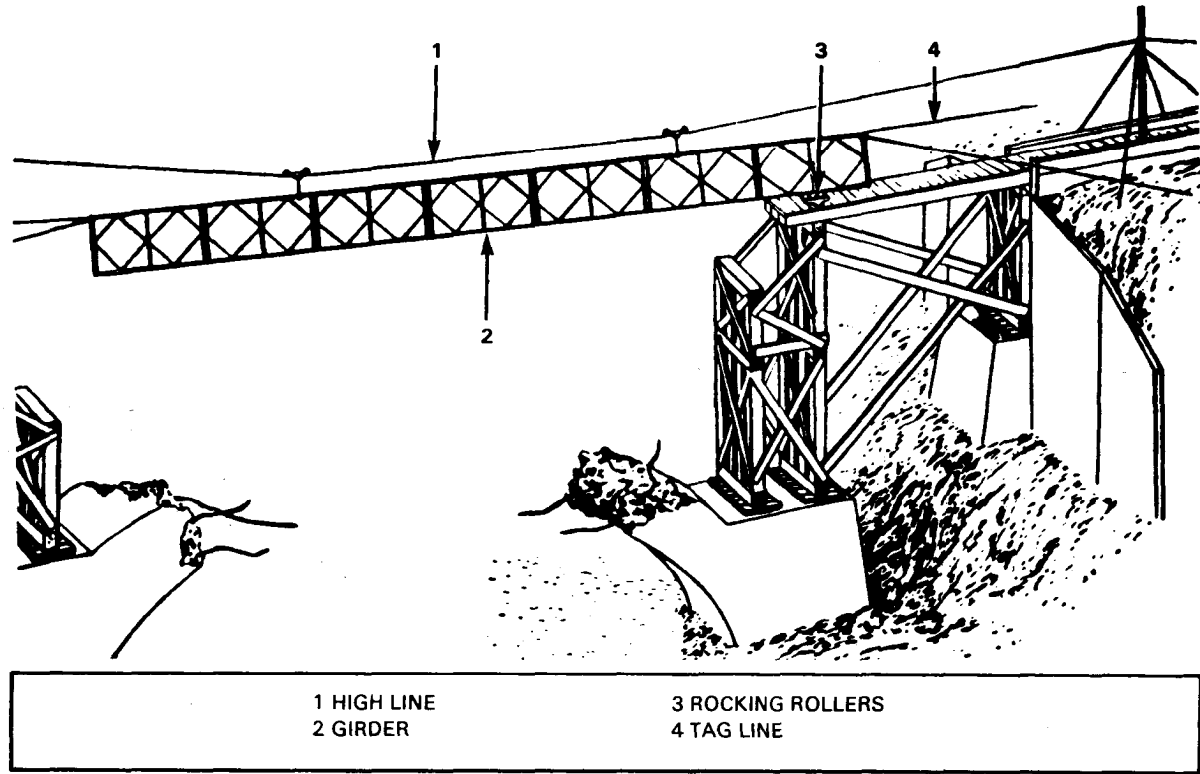

Figure 19-11 Launching a single-truss girder with a high line

Table 19-4 Weight, in tons, of single-truss and multitruss girders

NUMBER OF TRUSSES	SPACING OF OUTER TRUSSES	SPAN (ft)									
		30	40	50	60	70	80	90	100	110	120
One		0.9	1.2	1.5	1.8	2.1	2.4	2.6	2.9	3.2	3.5
Two	1'6"	1.9	2.5	3.2	3.8	4.4	5.1	5.7	6.4	7.0	7.6
Three	2'2½"	2.8	3.7	4.6	5.5	6.5	7.4	8.3	9.3	10.2	11.1
Three	3'0"	2.8	3.8	4.8	5.7	6.7	7.6	8.6	9.5	10.5	11.4
Four	2'2½"	3.7	4.9	6.2	7.4	8.7	9.9	11.1	12.4	13.6	14.8
Four	2'11"	3.7	4.9	6.1	7.4	8.6	9.8	11.1	12.3	13.5	14.7
Four	4'6"	3.8	5.1	6.4	7.7	9.0	10.3	11.5	12.8	14.1	15.4
Five	4'5"	4.7	6.2	7.8	9.3	10.9	12.5	14.0	15.6	17.1	18.7

Note:  
Without end posts

**JACKING DOWN**

Jack down the girders either with a jack under each end post or with jacks under an equalizing beam supporting the underside of the girder (Figure 19-12). Work the jacks in unison so the girder is lowered evenly. During the lowering, guy the girders to prevent

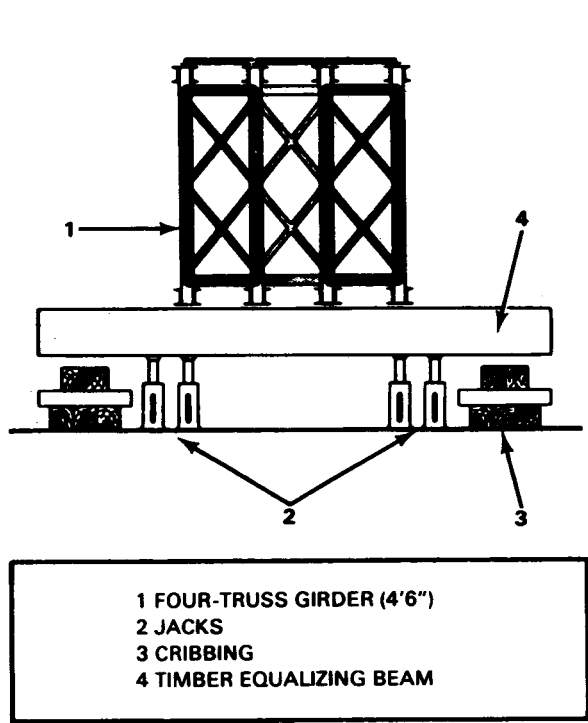

Figure 19-12 Jacks under four-truss girder using an equalizing beam

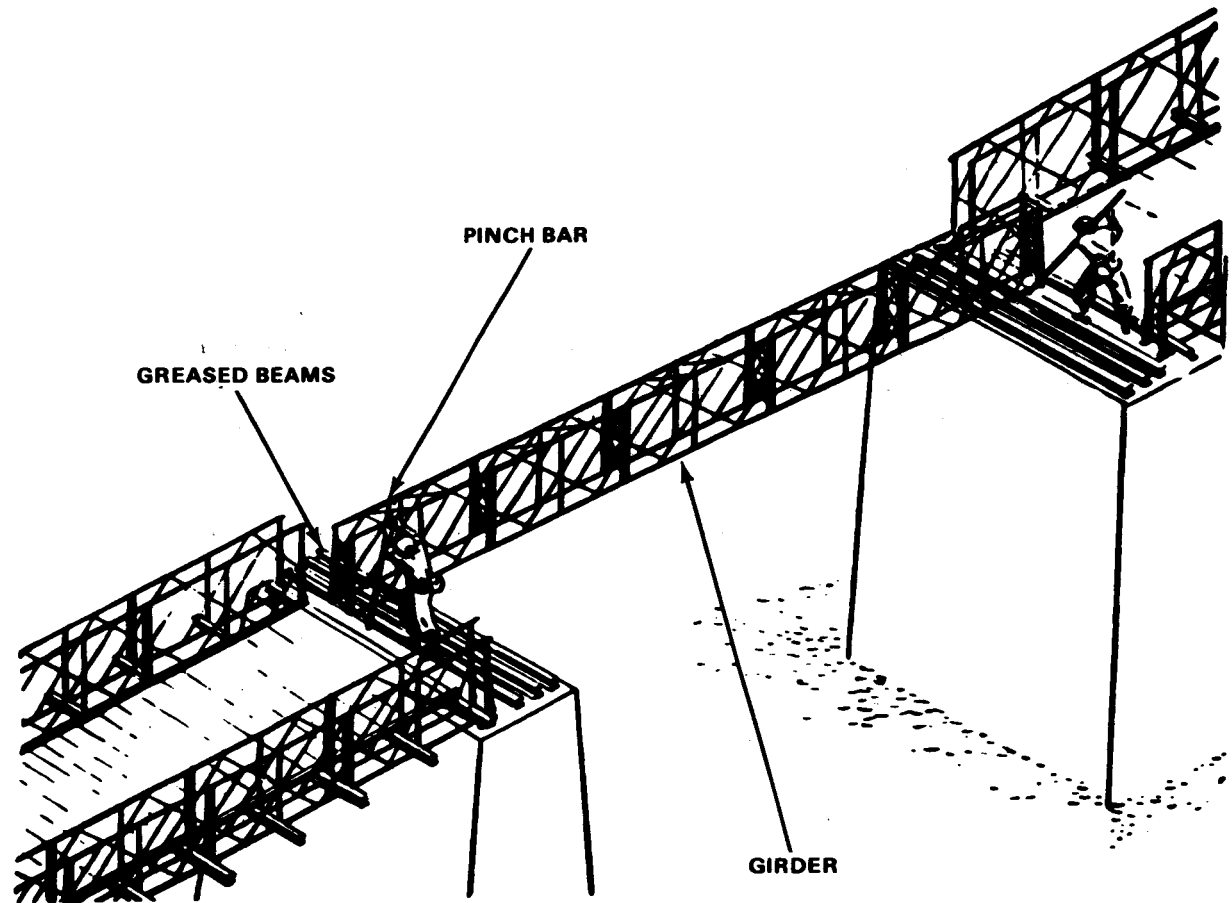

Figure 19-13 Skidding a girder into place by prying with pinchbars

overturning. To lower the girder in its final stage, place equalizer beam under top chord as in Figure 16-18. Place cribbing under the bottom chords or equalizer beam to prevent the girder from dropping if it slips off the jacks. If the distance to be lowered is great, lower the girder by successive stages. When truck-mounted cranes or gin poles are available at each end of the bridge, lower the girders directly on the bearings.

**SKIDDING AND SQUARING UP**

After launching, move the girder into position by truck cranes, or skid it into position on greased skidding beams by prying with panel levers or pinchbars (Figure 19-13). Panel-bridge stringers are preferred for skidding beams, but I-beams or timber beams may be used.

After the first girder is lined up with the existing bridge, square up the second girder with the first. If the trusses cannot be moved in a longitudinal direction without rollers, reinsert rollers after skidding.

## COMPLETION OF BRIDGE

For normal through-type assembly, complete the bridge bay by bay, working out from the near shore as follows:

- 1** Insert sway braces of first bay with adjusting collars on the same side of bridge. Use two lashings from centers of bottom brace to hold center of sway braces up until ends are pinned in place. Do not tighten.
- 2** Place transoms in first bay. A truck-mounted crane with gin pole on far bank may be used to telegraph transoms into place, or they may be placed by hand. In the telegraph method, attach to the transom both a line from the gin pole on the far bank and a line from the crane on the near bank. Then pick up the transom and place it by taking up the gin-pole line and slacking off on the crane line. Use a tag line on the transom to guide it. When handling it manually, push the transom out from the bank and swing it into position with the aid of ropes attached to the top chords. The transoms are difficult

to fit at first, but this becomes easier as more bays are completed.

- 3** Place stringers in first bay.
- 4** Remove vertical bracing frames and insert rakers. Do not tighten.
- 5** Repeat above procedure to install sway braces, transoms, stringers, and rakers in second bay.
- 6** After bracing members are inserted in second bay, tighten all bracing in first bay and lay chess and ribbands in first bay.
- 7** Add remainder of decking in the same manner.
- 8** Install ramps.

Deck-type bridges take either standard panel-bridge decking or expedient timber decking. For details of deck-type bridges, see Chapters 12 and 13.